

## 2. Power circuit (Low voltage)

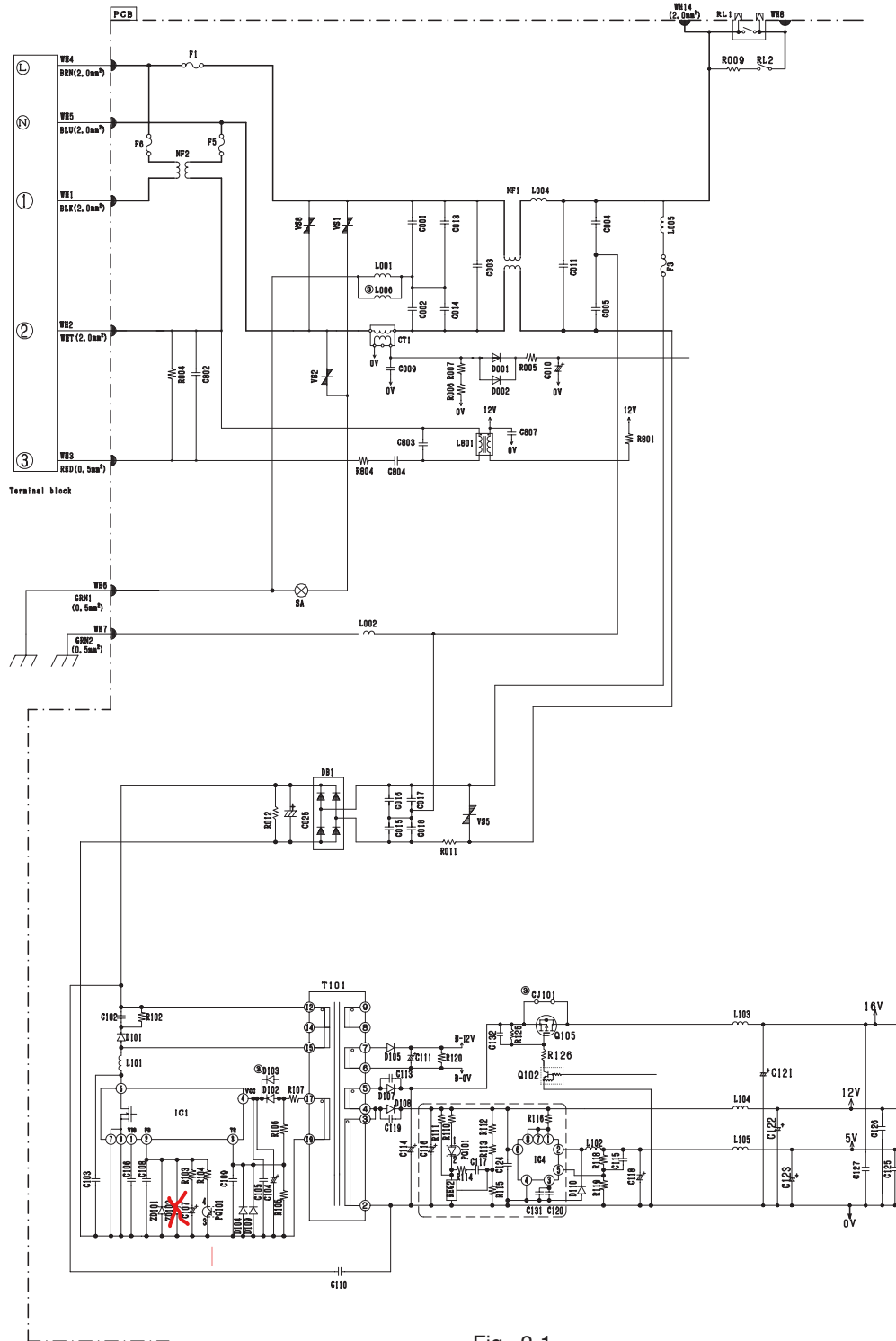

Fig. 2-1

- The 230V AC voltage is rectified to DC voltage (B-12V,16V,12V,5V) pass through switching control IC (ICI), switching transformer.

- (1) B-12V Power supply for electrical expansion valve.
- (2) 16V Power supply for IPM driver circuit of compressor and fan motor, IGBT action.
- (3) 12V Power supply for 4 way valve relay, power relay, inrush current relay, motor current amplification,
- (4) 5V Power supply for microcomputer, peripheral circuits.