

4-2. Outdoor Unit Control PCB

(3) Layout Diagram (CR-C486VEH)

4

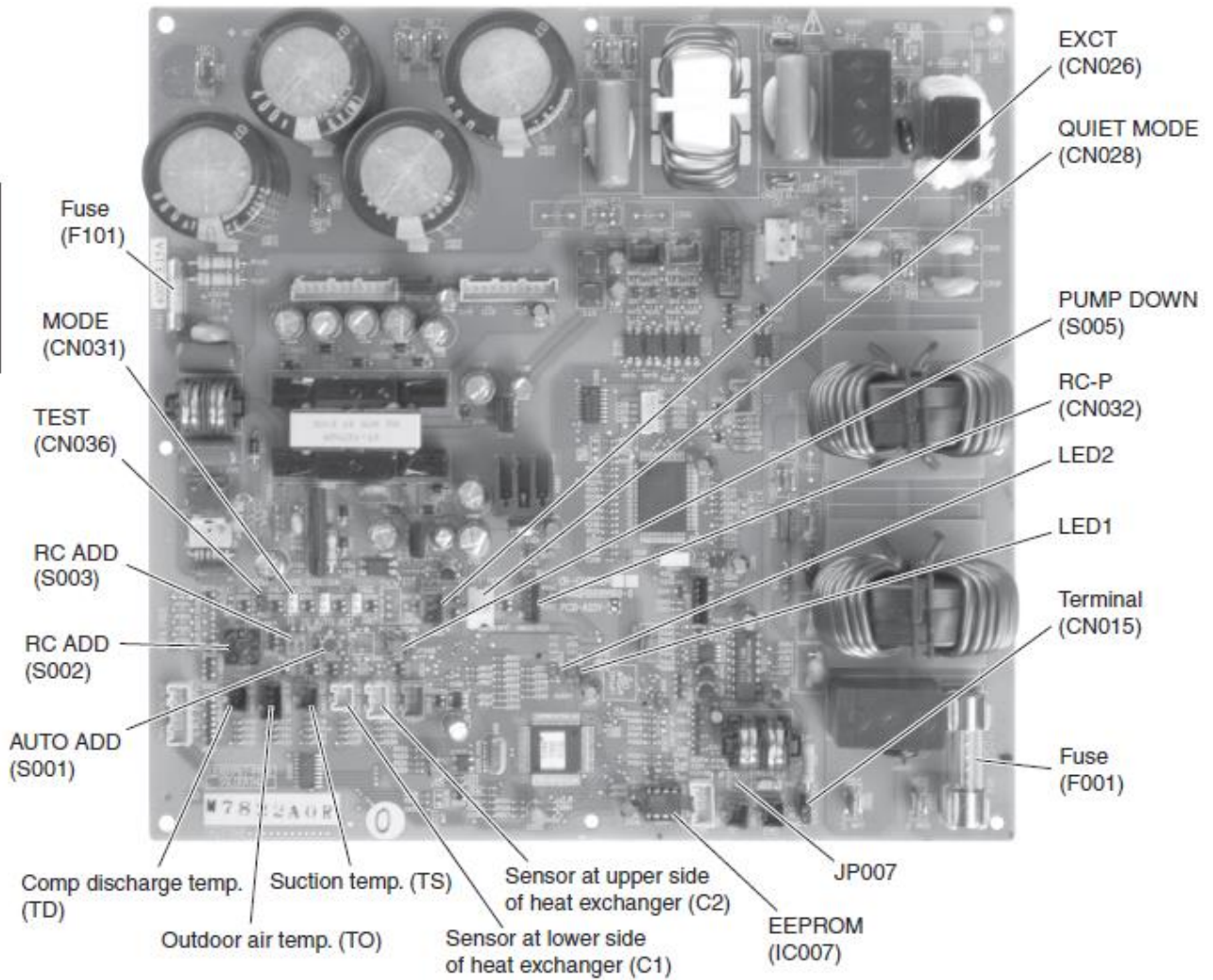

4-2. Outdoor Unit Control PCB (CR-C186VEH, CR-C256VEH)

(4-1) Explanation of Functions

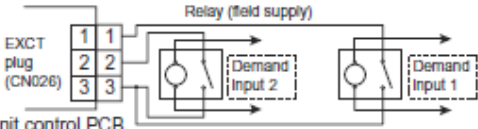
Auto Address (CN041)	<p>2P plug (white): Automatic address setting Pin</p> <ul style="list-style-type: none"> If the system address switch (S002: set to 0 at time of shipment) setting is other than "0" (central control), short circuit this pin once to automatically set the addresses at all indoor units which are in the same system, and are connected to that outdoor unit. During automatic address setting, the 2 LEDs (red) on the outdoor unit control PCB blink alternately. (Open circuit this pin again stops automatic address setting.) If automatic address setting is currently in progress at another system that is subject to central control, only LED 1 on the outdoor unit control PCB blinks to indicate that automatic address setting is in progress at another unit. If automatic address setting is in progress at another unit, automatic address setting cannot be made at this unit, even if CN041 is shorted. <p>* After the power is turned ON, automatic address setting will not be functioned for over 1 minute and 30 seconds.</p>																	
S002	<p>Rotary switch (10 positions, black): System address setting switch</p> <ul style="list-style-type: none"> This switch is set to 0 (1 system control) at the time of shipment. However the address for each system must be set when multiple systems are controlled or when central control is used. (Figure 1) If the system address is set to 0, automatic address setting is started when the power is turned ON. Therefore it is not necessary to use switch SW01 and perform automatic address setting in the case of single or simultaneous-operation multi control of a single system. When using central control for multiple systems, a maximum of 30 systems (maximum 64 units) can be connected. In the case of group control or central control, set the system address to a setting other than 0 (1 or above). If the number of systems is greater than 9, this switch can be used in combination with DIP switch S003 to set up to 30 systems. The setting can be made as high as 39, however all settings above 30 are handled as 30 for control. (For details, refer to Table 4-1.) If system addresses are duplicated (the same address exists more than once), LED 1 on the outdoor unit control PCB lights up, and alarm "L04" is displayed on the remote controller. 																	
S003	<p>DIP switch (2P, blue): System address 10s-digit and 20s-digit place setting switch</p> <ul style="list-style-type: none"> When setting 10 systems or more, set this switch in combination with S002. For 10 – 19 systems, set 1P (10s-digit place) to ON. For 20 – 29 systems, set 2P (20s-digit place) to ON, and set 1P (10s-digit place) to OFF. For 30 systems, set both 1P (10s-digit place) and 2P (20s-digit place) to ON. (For details, refer to Table 4-1.) 																	
PUMP DOWN (CN042)	<p>2P plug (white): Refrigerant recovery Pin</p> <ul style="list-style-type: none"> Short circuit this pin to perform refrigerant recovery control using cooling operation. The indoor unit fan will operate at HIGH and 55 Hz for a maximum of 10 minutes. When refrigerant recovery is completed, close the valves and open circuit this pin to stop the operation. 																	
Test (CN036)	<p>2P plug (red): Pin used for PCB inspection at the factory</p>																	
EXCT (CN026)	<p>3P plug (red): Can be used for demand control</p> <ul style="list-style-type: none"> The operating ranges are shown in the table. <div style="display: flex; align-items: center;"> <div style="flex: 1;">  <p style="font-size: small;">Outdoor unit control PCB</p> </div> <div style="flex: 1;"> <table border="1" data-bbox="1038 1704 1385 1865"> <thead> <tr> <th colspan="2">Short-circuited</th> <th rowspan="2">Operating range</th> </tr> <tr> <th>2P and 3P</th> <th>1P and 3P</th> </tr> </thead> <tbody> <tr> <td>0</td> <td>0</td> <td>No limit</td> </tr> <tr> <td>0</td> <td>1</td> <td>100% at shipment</td> </tr> <tr> <td>1</td> <td>0</td> <td>70% at shipment</td> </tr> <tr> <td>1</td> <td>1</td> <td>OFF</td> </tr> </tbody> </table> </div> </div> <p>Note 1: The maximum length of the wiring between the outdoor unit PCB and the relay is 2 m.</p> <ul style="list-style-type: none"> Lead wire with 3P plug (special-order part : 623-182-0530) Relay (field supply) contact input specifications : minimum compatible load 0.1mA 	Short-circuited		Operating range	2P and 3P	1P and 3P	0	0	No limit	0	1	100% at shipment	1	0	70% at shipment	1	1	OFF
Short-circuited		Operating range																
2P and 3P	1P and 3P																	
0	0	No limit																
0	1	100% at shipment																
1	0	70% at shipment																
1	1	OFF																

4-2. Outdoor Unit Control PCB (CR-C486VEH)

(4-2) Explanation of Functions

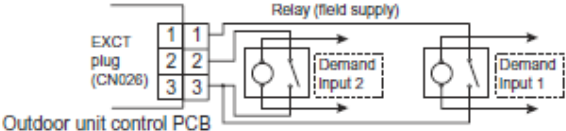
AUT ADD (S001)	<p>Push-button switch (black): Automatic address setting switch</p> <ul style="list-style-type: none"> If the system address switch (S002: set to 0 at time of shipment) setting is other than "0" (central control), press this switch once to automatically set the addresses at all indoor units which are in the same system, and are connected to that outdoor unit. During automatic address setting, the 2 LEDs (red) on the outdoor unit control PCB blink alternately. (Pressing this switch again stops automatic address setting.) If automatic address setting is currently in progress at another system that is subject to central control, only LED 1 on the outdoor unit control PCB blinks to indicate that automatic address setting is in progress at another unit. If automatic address setting is in progress at another unit, automatic address setting cannot be started at this unit, even if S001 is pressed. 																	
S002	<p>Rotary switch (10 positions, black): System address setting switch</p> <ul style="list-style-type: none"> This switch is set to 0 (1 system control) at the time of shipment. However the address for each system must be set when multiple systems are controlled or when central control is used. (Figure 4-1) If the system address is set to 0, automatic address setting is started when the power is turned ON. Therefore it is not necessary to use switch SW01 and perform automatic address setting in the case of single or simultaneous-operation multi control of a single system. When using central control for multiple systems, a maximum of 30 systems (maximum 64 units) can be connected. In the case of group control or central control, set the system address to a setting other than 0 (1 or above). If the number of systems is greater than 9, this switch can be used in combination with DIP switch S003 to set up to 30 systems. The setting can be made as high as 39, however all settings above 30 are handled as 30 for control. (For details, refer to Table 4-1.) If system addresses are duplicated (the same address exists more than once), LED 1 on the outdoor unit control PCB lights up, and alarm "L04" is displayed on the remote controller. 																	
S003	<p>DIP switch (2P, blue): System address 10s-digit and 20s-digit place setting switch</p> <ul style="list-style-type: none"> When setting 10 systems or more, set this switch in combination with S002. For 10 – 19 systems, set 1P (10s-digit place) to ON. For 20 – 29 systems, set 2P (20s-digit place) to ON, and set 1P (10s-digit place) to OFF. For 30 systems, set both 1P (10s-digit place) and 2P (20s-digit place) to ON. (For details, refer to Table 4-1.) 																	
PUMP DOWN (S005)	<p>Push-button switch (red): Refrigerant recovery switch</p> <ul style="list-style-type: none"> Press this switch to perform refrigerant recovery control using cooling operation. The indoor unit fan will operate at HIGH and 55 Hz for a maximum of 10 minutes. When refrigerant recovery is completed, close the valves and press this switch to stop the operation. 																	
Test (CN036)	<p>2P plug (red): Pin used for PCB inspection at the factory</p>																	
EXCT (CN026)	<p>3P plug (red): Can be used for demand control</p> <ul style="list-style-type: none"> The operating ranges are shown in the table. <div data-bbox="437 1760 1005 1890" style="display: flex; align-items: center;">  <table border="1" data-bbox="1037 1715 1385 1877" style="margin-left: 20px;"> <thead> <tr> <th colspan="2">Short-circuited</th> <th rowspan="2">Operating range</th> </tr> <tr> <th>2P and 3P</th> <th>1P and 3P</th> </tr> </thead> <tbody> <tr> <td>0</td> <td>0</td> <td>No limit</td> </tr> <tr> <td>0</td> <td>1</td> <td>100% at shipment</td> </tr> <tr> <td>1</td> <td>0</td> <td>70% at shipment</td> </tr> <tr> <td>1</td> <td>1</td> <td>OFF</td> </tr> </tbody> </table> </div> <p>Note 1: The maximum length of the wiring between the outdoor unit PCB and the relay is 2 m.</p> <ul style="list-style-type: none"> Lead wire with 3P plug (special-order part : 623-182-0530) Relay (field supply) contact input specifications : minimum compatible load 0.1mA 	Short-circuited		Operating range	2P and 3P	1P and 3P	0	0	No limit	0	1	100% at shipment	1	0	70% at shipment	1	1	OFF
Short-circuited		Operating range																
2P and 3P	1P and 3P																	
0	0	No limit																
0	1	100% at shipment																
1	0	70% at shipment																
1	1	OFF																

4-2. Outdoor Unit Control PCB (CR-C186VEH, CR-C256VEH, CR-C486VEH)

(4-3) Explanation of Functions

SILENT
(CR-C186VEH)
(CR-C256VEH)
QUIET MODE
(CR-C486VEH)
(CN028)

2P plug (white): Enables operation in quiet mode.

- The outdoor unit fan and compressor frequencies are subject to limits during operation.
- Low-noise operation is enabled when the relay is turned ON. (Non-voltage contact "a")

● Example of wiring

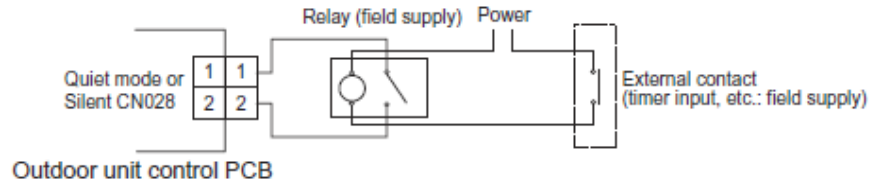

Note 2: The maximum length of the wiring between the outdoor unit PCB and the relay is 2 m.

- Lead wire with 2P plug (special-order part: 623-161-2098)
- Relay, (field supply) contact input specifications: DC 5 V, 0.5 mA
(Recommended relay: Fuji Electric HH62SW, compatible with micro contacts)
- Use a commercially available timer (such as the Omron H5 daily time switch).

4

Table 4-1. Method of System Address Setting

[S002 (rotary, black), S003 (2P DIP switch, blue)]

	Outdoor system address No.	S002 setting (system address switch)	S003 setting	
			1P (10s-digit place)	2P (20s-digit place)
Central control	1	0	OFF	OFF
	2	1	OFF	OFF
	3	2	OFF	OFF
	4	3	OFF	OFF
	5	4	OFF	OFF
	6	5	OFF	OFF
	7	6	OFF	OFF
	8	7	OFF	OFF
	9	8	OFF	OFF
	10	9	OFF	OFF
	11	0	ON	OFF
	12	1	ON	OFF
	13	2	ON	OFF
	14	3	ON	OFF
	15	4	ON	OFF
	16	5	ON	OFF
	17	6	ON	OFF
	18	7	ON	OFF
	19	8	ON	OFF
	20	9	ON	OFF
	21	0	OFF	ON
	22	1	OFF	ON
	23	2	OFF	ON
	24	3	OFF	ON
	25	4	OFF	ON
	26	5	OFF	ON
	27	6	OFF	ON
	28	7	OFF	ON
	29	8	OFF	ON
	30	9	OFF	ON

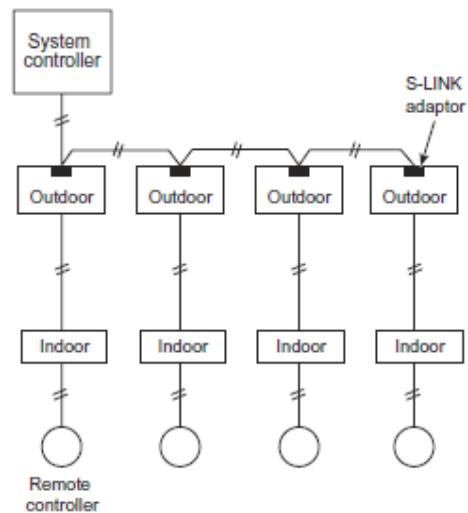

Fig. 1

4-3. Indoor Unit Control PCB Switches and Functions

[Indoor unit control PCB]

- T10 (CN61):** **6P plug (YEL)** / Used for remote control operation. (Refer to the Remote Control Section.)
Control items: (1) Start/stop input (2) Remote controller prohibit input
(3) Start signal output (4) Alarm signal output
- EXCT (CN73):** **2P plug (RED)** / Can be used for demand control. When input is present, forces the unit to operate with the thermostat OFF.
- DISP (CN72):** **2P plug (WHT)** / Short-circuiting this plug allows operation to be controlled by the remote controller even when an outdoor unit is not connected. (In this case, alarm "E04," which indicates trouble in the serial communication between the indoor and outdoor unit, does not occur.)
- CHK:** **2P plug (WHT)** / Test pin. Short-circuiting this pin allows the indoor FM (H fan speed), drain pump, flap motor (F1 position), and electronic expansion valve full-open position to be checked.
However this function turns OFF if the indoor unit protection mechanism is activated. The components will operate even if the remote controller and outdoor unit are not connected, however the remote control cannot be used for control even if it is connected. This plug can be used for short-term tests.
- JP1 (J01):** **Jumper wire** / Allows selection of the T10 terminal start/stop signal. (Refer to the Remote Control Section.)
Setting at time of shipment: Pulse signal
Jumper wire cut: Static signal (continuous signal)
- Fan drive:** **2P plug (WHT)** / This terminal sends the signal to the ventilation fan when a commercially available ventilation fan is operated by the FAN button on the wired remote controller. (Refer to the Remote Control Section.)
Use a ventilation fan which can accept the no-voltage contact A signal as the external input signal.
- Filter:** **2P (WHT)** / This terminal is used to connect contact input from the differential-pressure switch, used to detect filter clogging. When the contact is ON, "FILTER" appears on the display of the wired remote controller.
- Power LED:** **LED (RED)** / Illuminates when the power is ON. Flashes when there is trouble with the EEPROM (IC10, IC010: nonvolatile memory).
- EEPROM (IC10):** **Nonvolatile memory** / Used to store model information and other data. When replacing the PCB, remove the EEPROM from the old PCB and install it onto the new PCB. If there is IC trouble, replace with a new IC (provided with the servicing PCB), and set the necessary information using the wired remote controller. (For the setting procedure, refer to the servicing technical materials.)
- GRL (CN20):**
- For AC fan motor (CR-UXRP71B-B) – 3P (YEL)
 - For DC fan motor (CR-SXRP56B-B) – 5P (BLU)

- There are 5P, 6P, 7P and 8P control PCB types for indoor units.

