

3-1 Indoor Unit

① SPW-T253GH56, SPW-T363GH56, SPW-T483GH56

• Electric Wiring Diagram

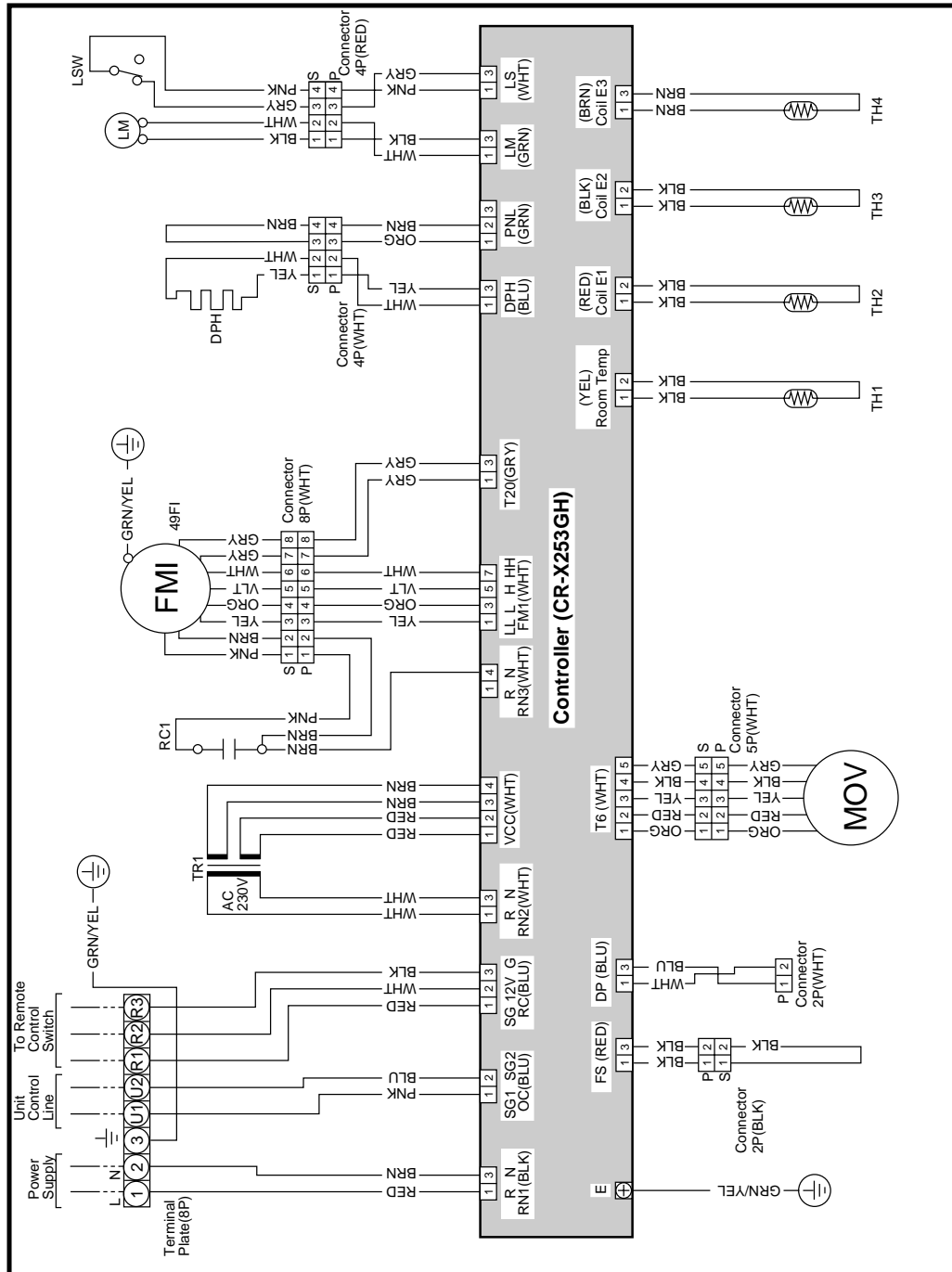

① 854-2-5268-412-00-1 (T)



3-1 Indoor Unit

① SPW-T253GH56, SPW-T363GH56, SPW-T483GH56

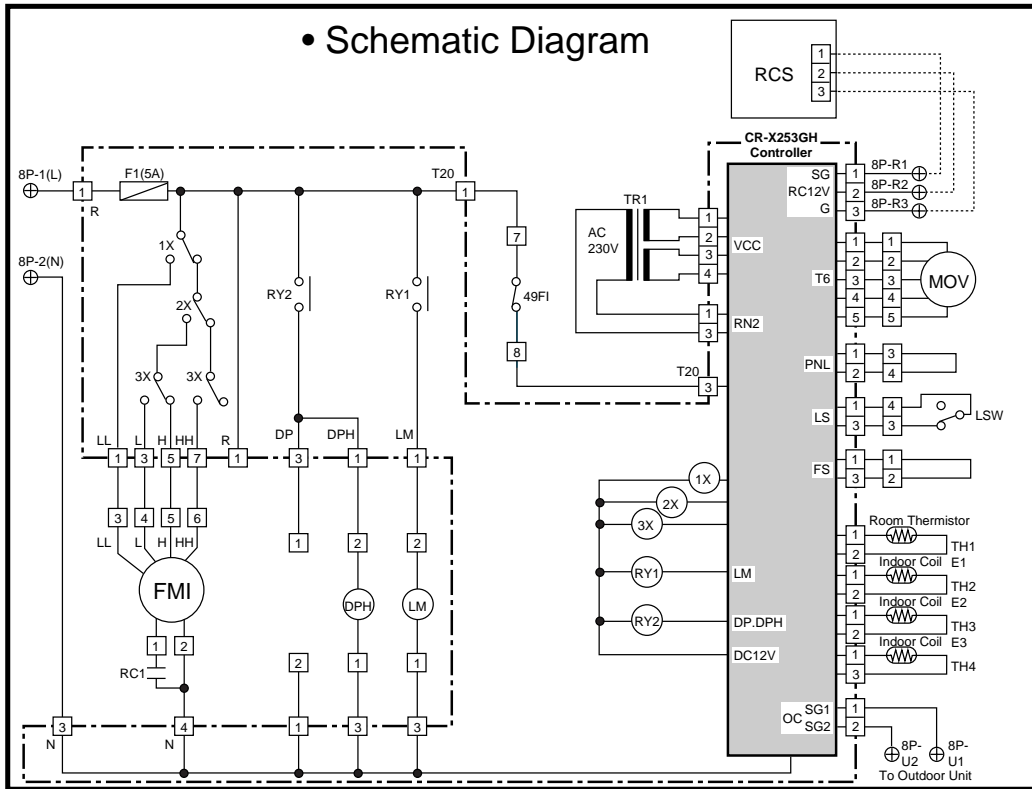

Symbols	Description	Symbols	Description
FMI	Indoor Fan Motor	TH3	Thermistor (Indoor Coil E2)
49FI	Indoor Motor Thermal Protector	TH4	Thermistor (Indoor Coil E3)
RC1	Running Capacitor	CR-X253GH	Indoor Controller
F1	Fuse	⊕	Terminal Plate
LM	Auto Louver Motor	□	Connector
TR1	Power Transformer	⊕	Terminal
1X-3X	Auxiliary Relay	DPH	Dew Proof Heater
RY1-RY2	Auxiliary Relay	LSW	Limit Switch
MOV	Motor Operated Valve	FS	Float Switch
RCS	Remote Control Switch		
TH1	Room Thermistor		
TH2	Thermistor (Indoor Coil E1)		

© 854-2-5268-412-00-1 (T)



3-2 Outdoor Unit

② SPW-C253GH8



• Electric Wiring Diagram

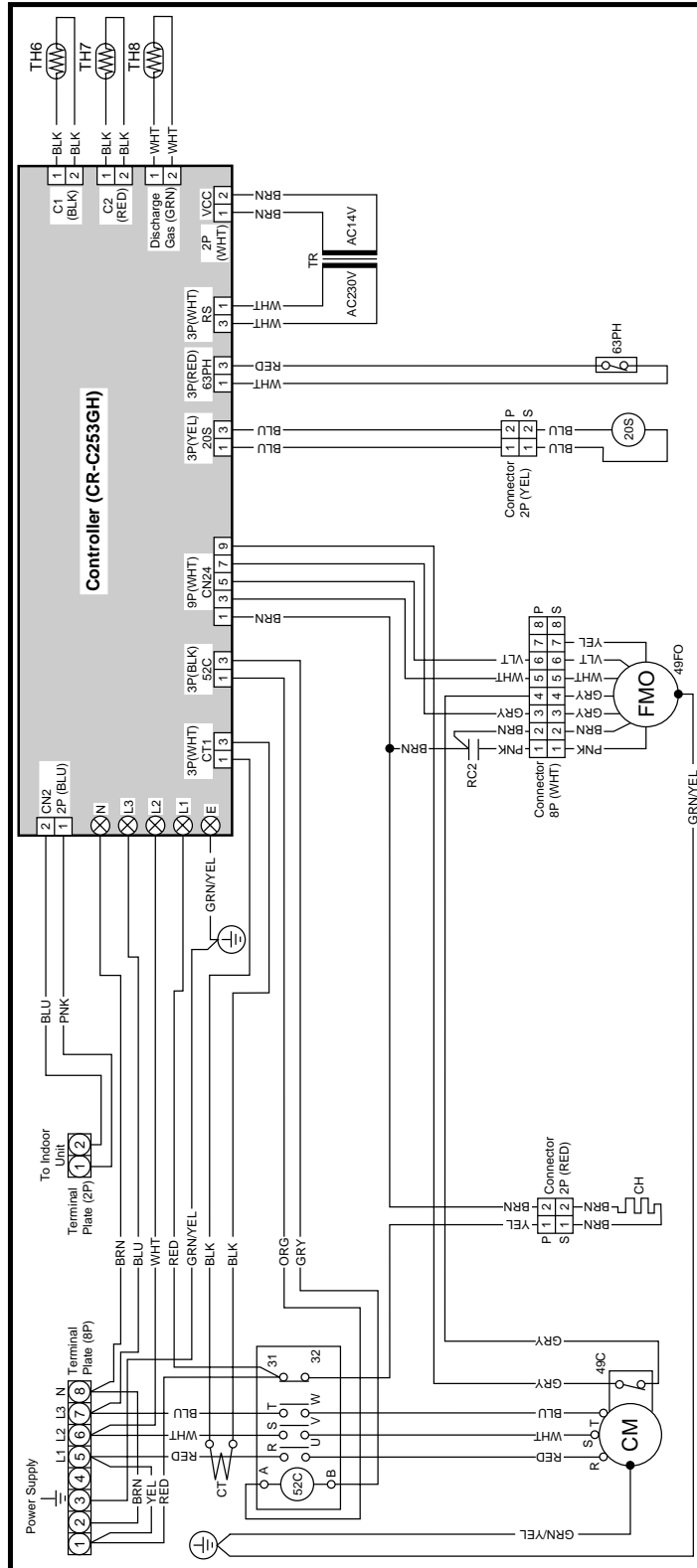

⑧ 854-2-5268-453-00-0 (C253GH8)

3-2 Outdoor Unit

② SPW-C253GH8

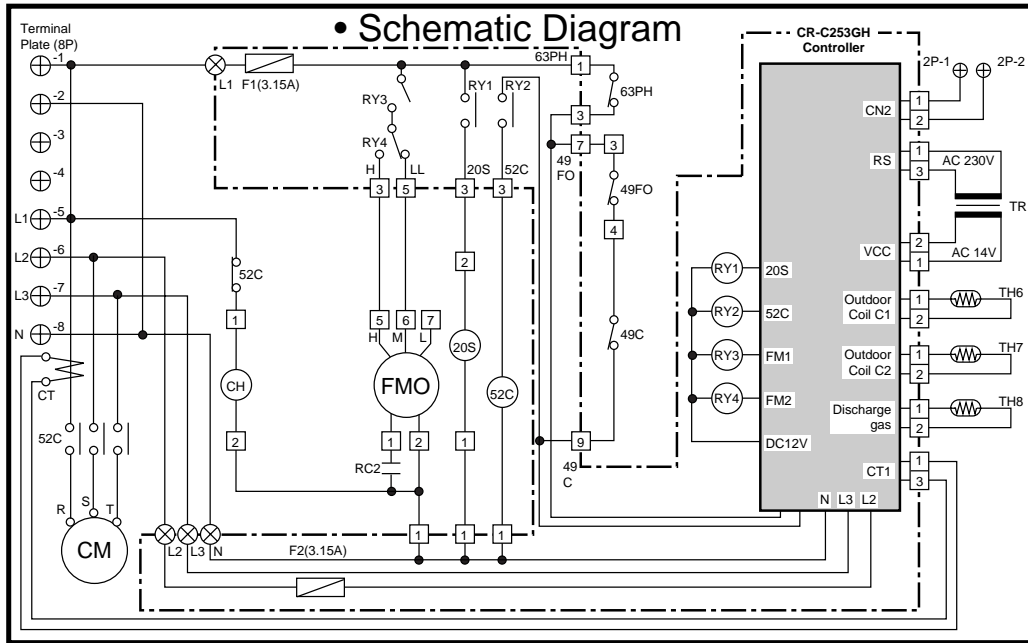

Symbols	Description	Symbols	Description
CM	Compressor Motor	CR-C253GH	Outdoor Controller
FMO	Outdoor Fan Motor	RY1-4	Auxiliary Relay
52C	Compressor Motor Magnetic Contactor	⊕	Terminal Plate
49C	Compressor Motor Thermal Protector	⊗	Terminal
49FO	Outdoor Fan Motor Thermal Protector	□	Connector
63PH	High Pressure Switch		
CT	Current Transmitter		
RC2	Running Capacitor		
TR	Power Transformer		
CH	Crank Case Heater		
20S	Four Way Valve		
F1,2	Fuse		
TH6	Thermistor (Outdoor Coil C1)		
TH7	Thermistor (Outdoor Coil C2)		
TH8	Thermistor (Discharge Gas)		

© 854-2-5268-453-00-0 (C253GH8)

