



Technical Guide

HORIZONTAL DISCHARGE SPLIT-SYSTEM AIR CONDITIONERS

13 SEER - R-410A - 1 PHASE
1.5 THRU 5 NOMINAL TONS

MODELS: TCHD18 THRU 60



Due to continuous product improvement, specifications are subject to change without notice.

Visit us on the web at
www.upgnet.com and www.york.com

Additional rating information can be found at
www.ahridirectory.org

WARRANTY SUMMARY

Extended 10-year limited parts warranty.

Standard 10-year limited compressor warranty.

Extended 10-year limited parts warranty requires online registration within 90 days of purchase for replacement or closing for new home construction.

*Does not apply to R-22 models, 3-Phase models, or internet sales.
See Limited Warranty certificate in User's Information Manual for details.

DESCRIPTION

The 13 SEER Series condensing unit is the outdoor part of a versatile system of air conditioning. It is designed to be custom-matched with one of UPG's complete line of evaporator sections, with each serving a specific function. Matching Air Handlers are available for upflow, downflow, or horizontal applications to provide a complete system. Electric Heaters are available, if required. Add-On coils are available for use with upflow, downflow, or horizontal furnaces and air handlers.

FEATURES

- **Performance-** Efficiency levels from 13.0 SEER/11.0 EER with a loose coil up to 16.0 SEER/14.0 EER (some models) when coupled with an ECM indoor blower.
- **Small Footprint-** Compact "slim-line" design allows for easy installation in tight spaces. Units can be stacked two-high with approved stacking kit.
- **QuietDrive™ System** - The combination of a swept-wing fan, rigid base pan, isolated compressor compartment, and quiet scroll compressor reduce sound to as low as 70 dBA.
- **Low Operating Sound Levels-** The swept-wing condenser fan in blow-through configuration provides for whisper-quiet operation by allowing air to flow smoothly and efficiently across the fan tips.
- **Quality Condenser Coils-** The coil is constructed of aluminum microchannel tubing and enhanced aluminum fins for compact size and increased efficiency.
- **Environmentally Friendly Refrigerant** - The next generation refrigerant R-410A delivers environmentally friendly performance with zero ozone depletion.
- **Durable Finish** - Heavy-gage steel cabinet and tubular base rails provide added support.
- **Aesthetic-** Powder paint "Champagne" color provides an attractive retail finish.
- **Commercial Applications-** The TCHD 3 Phase Series is also available in 208/230-3-60 and 460-3-60 voltages in the 2½, 3, 4, & 5 ton models.
- **Other Features:**
 - Factory supplied filter drier
 - High pressure switch, low pressure switch
 - Accumulator and crankcase heater in all sizes
 - Up to 200' line set out of the box
 - Zero lot line - only 6" minimum clearance from structure
- **Agency Listed** - Safety certified by CSA to UL 1995 / CSA 22.2. Performance certified to ANSI/AHRI Standard 210/240 in accordance with the Unitary Small Equipment certification program.

Physical and Electrical Data

MODEL	TCHD18 S41S3	TCHD24 S41S4	TCHD30 S41S3	TCHD36 S41S3	TCHD48 S41S3	TCHD60 S41S3
Unit Supply Voltage	208-230V, 1 ϕ , 60Hz					
Normal Voltage Range ¹	187 to 252					
Minimum Circuit Ampacity	11.8	18.3	17.5	23.1	27.1	34.3
Max. Overcurrent Device Amps ²	20	30	30	40	45	60
Min. Overcurrent Device Amps ³	15	20	20	25	30	35
Compressor	Type	Scroll	Scroll	Scroll	Scroll	Scroll
	Rated Load Amps	9.0	13.5	12.8	17.3	20.5
	Locked Rotor Amps	48.0	58.3	64.0	96.7	115.0
Crankcase Heater	Yes	Yes	Yes	Yes	Yes	Yes
Factory External Discharge Muffler	No	No	No	No	No	No
Factory External Check Valve	No	No	No	No	No	No
HS Kit Required with TXV ⁴	No	No	No	No	No	No
Fan Diameter Inches	17.5	23	23	23	23	23
Fan Motor	Rated HP	1/8	1/4	1/4	1/4	1/4
	Rated Load Amps	0.6	1.5	1.5	1.5	1.5
	Nominal RPM	840	850	850	850	850
	Nominal CFM	1150	3200	3200	3200	3050
Coil	Face Area Sq. Ft.	5.76	11.96	11.96	11.96	13.96
	Rows Deep	1	1	1	1	1
	Fins / Inch	23	23	23	23	23
Refrigerant Lines ⁵	Max. Length	200	200	200	200	200
	Max. Lift	65	65	65	65	65
	Max. Drop	150	150	150	150	150
	Liquid Line Set OD (Field Installed)	3/8	3/8	3/8	3/8	3/8
	Vapor Line Set OD (Field Installed)	3/4	3/4	3/4	3/4	7/8
Unit Charge (Lbs. - Oz.) ⁶	2 - 10	4 - 1	4 - 0	4 - 8	5 - 5	5 - 6
Charge Per Foot, Oz.	0.62	0.62	0.62	0.62	0.67	0.67
Operating Weight Lbs.	130	195	195	215	240	250

1. Rated in accordance with AHRI Standard 110-2012, utilization range "A".
2. Dual element fuses or HACR circuit breaker. Maximum allowable overcurrent protection.
3. Dual element fuses or HACR circuit breaker. Minimum recommended overcurrent protection.
4. See Hard Start Kit Accessory Installation Manual for Hard Start Kit part number for each model.
5. When more than 50 feet of interconnecting tubing and more than 30 feet of vertical lift is used, consult the Application Data (part number 247077). For long-line applications, interconnecting lines over 100 feet must be installed with liquid line solenoid.
6. The Unit Charge is correct for the outdoor unit, smallest matched indoor unit, and 15 feet of refrigerant tubing. For tubing lengths other than 15 feet, add or subtract the amount of refrigerant, using the difference in actual lineset length (not equivalent length) multiplied by the per foot value.

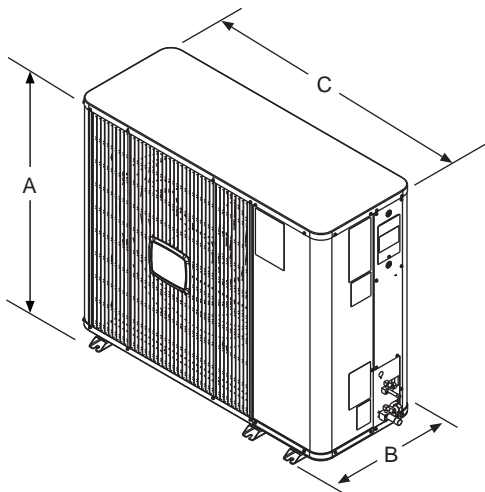

Unit Model	Dimensions (Inches)			Refrigerant Connection Service Valve Size	
	A	B	C	Liquid	Vapor
18	25-1/4	17-1/2	37-1/4	3/8	3/4
24	37-1/4	20	45		
30	37-1/4	20	45		
36	37-1/4	20	45		
48	43-1/4	20	45	7/8	
60	43-1/4	20	45		

All dimensions are in inches and are subject to change without notice.
 Overall height is from bottom of mounting feet to top of unit.
 Overall length and width include mounting feet and screw heads.

System Charge for Various Matched Systems						
Outdoor Unit	TCHD18S41S3	TCHD24S41S4	TCHD30S41S3	TCHD36S41S3	TCHD48S41S3	TCHD60S41S3
Required TXV ^{1,2}	4F1	4F1	4G1	4G1	4J1	4K1
Indoor Unit ^{3,4,5}	Additional Charge, Oz					
AHE18B	4	–	–	–	–	–
AHE24B	17	14	–	–	–	–
AHE30B	17	14	10	–	–	–
AHE36C	24	20	16	12	–	–
AHE42D	–	32	27	22	–	–
AHE48D	–	–	–	–	11	–
AHE60D	–	–	–	–	16	13
AHR18B	4	–	–	–	–	–
AHR24B	–	14	–	–	–	–
AHR30B	–	–	10	–	–	–
AHR36B	–	–	16	12	–	–
AHR42C	–	–	–	22	–	–
AHR48D	–	–	–	–	11	–
AHR60D	–	–	–	–	16	–
AHV18B	0	–	–	–	–	–
AHV24B	13	9	–	–	–	–
AHV30B	14	9	0	–	–	–
AHV36C	21	16	7	0	–	–
AHV42D	–	–	18	11	–	–
AHV48D	–	–	–	10	0	–
AHV60D	–	–	–	–	4	0
FC/MC/PC18	4	–	–	–	–	–
FC/MC/PC24	4	0	–	–	–	–
FC/MC/PC32	17	14	10	6	–	–
FC/MC/PC35	17	14	10	6	–	–
FC/MC/PC37	24	21	16	12	–	–
FC/MC/PC43	–	20	16	0	–	–
FC/MC/PC48	–	32	27	22	0	–
FC/MC/PC60	–	–	–	–	10	–
FC/MC62	–	–	–	–	16	0
FC64	–	–	–	–	25	11
HD24	26	17	–	–	–	–
HD36	32	20	14	11	–	–
HD48	–	–	–	33	24	–
HD60	–	–	–	–	30	22
UC18	5	–	–	–	–	–
UC24	9	5	–	–	–	–
UC48	–	25	21	17	6	–
UC60	–	–	–	–	11	–

Some of the combinations shown in the above System Charge table require Advanced Main Air Circulating Fan indoor product. For approved coil only matches, please see the "COOLING CAPACITY - Upflow, Downflow & Horizontal Furnaces and Coils" table.

FOOTNOTES:

1. For applications requiring a TXV use S1-1TVM*** series kit.
2. A TXV kit must be used with these indoor units to obtain system performance.
3. Systems matched with furnaces or air handlers not equipped with blower-off delays may require blower Time Delay Kit S1-2FD06700224.
4. PC coils cannot be used in downflow or horizontal applications. FC coils cannot be used in horizontal applications.
5. Refer to Cooling Performance Data tables for actual system performance for specified system matches.

PROCEDURES:

1. Unit factory charge listed on the unit nameplate includes refrigerant for the outdoor unit, the smallest matched indoor unit, and 15 feet of interconnecting line tubing.
2. Verify the TXV and additional charge required for specific matched indoor unit in the system using the above table.
3. Add additional charge for the amount of interconnecting line tubing greater than 15 feet at the rate specified in Physical and Electrical Data Table.
4. For indoor matches requiring additional charge, the refrigerant needs to be weighed in for specific matched indoor unit and actual lineset length.
5. Permanently mark the unit nameplate with the total system charge. Total System Charge = Base Charge (as shipped) + charge adder for matched indoor unit + charge adder for actual lineset length.

COOLING CAPACITY - With Air Handler Coils

UNIT MODEL	AIR HANDLER		COIL MODEL 1	COOLING				
	MODEL	WIDTH		RATED CFM	NET MBH		SEER	EER
					TOTAL	SENS.		
13 SEER AC WITH AIR HANDLERS								
TCHD18S41S3	AHE18B	17.5	-	610	18.1	12.8	14.50	12.00
TCHD18S41S3	AHE24B	17.5	-	585	18.3	13.0	14.75	12.25
TCHD18S41S3	AHE30B	17.5	-	585	18.3	13.0	14.75	12.25
TCHD18S41S3	AHE36C	21.0	-	730	19.4	14.6	15.25	12.75
TCHD18S41S3	AHR18B	17.5	-	665	17.9	12.8	13.00	11.00
TCHD18S41S3	AHV18B	17.5	-	615	18.0	12.7	14.25	11.50
TCHD18S41S3	AHV24B	17.5	-	580	18.2	12.8	14.50	11.75
TCHD18S41S3	AHV30B	17.5	-	700	18.4	13.8	14.50	11.75
TCHD18S41S3	AHV36C	21.0	-	670	18.6	13.7	15.00	12.00
TCHD18S41S3	MV12B	17.5	FC/MC24B	600	18.4	12.9	14.50	12.15
TCHD18S41S3	MV12B	17.5	FC/MC35B	600	18.3	13.1	14.50	12.00
TCHD18S41S3	MX12BN21	17.5	FC/MC18B	600	18.0	12.7	14.25	11.50
TCHD18S41S3	MX12BN21	17.5	FC/MC24B	600	18.4	13.0	14.85	12.00
TCHD18S41S3	MX12BN21	17.5	FC/MC35B	600	18.4	13.1	14.80	12.00
TCHD18S41S3	MX16CN21	21.0	FC/MC35C	625	18.1	12.8	13.25	10.75
TCHD24S41S4	AHE24B	17.5	-	795	24.0	17.0	15.50	13.00
TCHD24S41S4	AHE30B	17.5	-	795	24.0	17.0	15.50	13.00
TCHD24S41S4	AHE36C	21.0	-	855	24.4	17.8	16.00	13.50
TCHD24S41S4	AHE42D	24.5	-	820	24.4	17.3	16.25	13.50
TCHD24S41S4	AHR24B	17.5	-	740	23.4	16.1	14.25	12.00
TCHD24S41S4	AHV24B	17.5	-	710	23.8	16.4	15.50	12.75
TCHD24S41S4	AHV30B	17.5	-	775	23.6	16.3	15.25	12.50
TCHD24S41S4	AHV36C	21.0	-	760	24.2	17.1	15.75	13.25
TCHD24S41S4	MV12B	17.5	FC/MC24B	830	24.2	17.1	15.75	13.25
TCHD24S41S4	MV12B	17.5	FC/MC35B	800	24.2	16.8	15.50	13.00
TCHD24S41S4	MV12B	17.5	FC/MC43B	800	24.4	17.3	15.75	13.00
TCHD24S41S4	MV12D	24.5	FC/MC48D	845	24.4	17.7	16.75	13.50
TCHD24S41S4	MX12BN21	17.5	FC/MC24B	800	24.2	17.1	15.50	13.00
TCHD24S41S4	MX12BN21	17.5	FC/MC35B	800	24.0	16.8	15.50	12.75
TCHD24S41S4	MX12BN21	17.5	FC/MC43B	800	24.4	17.3	15.75	13.00
TCHD24S41S4	MX12DN21	24.5	FC/MC48D	800	24.4	17.0	16.25	13.50
TCHD24S41S4	MX16CN21	21.0	FC/MC35C	800	24.0	16.8	15.00	12.50
TCHD24S41S4	MX16CN21	21.0	FC/MC43C	800	24.2	17.2	15.50	12.75
TCHD24S41S4	MX16CN21	21.0	FC/MC48C	800	24.4	17.1	15.50	13.00
TCHD30S41S3	AHE30B	17.5	-	985	28.4	21.2	14.75	13.00
TCHD30S41S3	AHE36C	21.0	-	1000	29.0	21.8	15.50	13.50
TCHD30S41S3	AHE42D	24.5	-	1000	29.4	22.2	16.00	14.00
TCHD30S41S3	AHR30B	17.5	-	1065	28.2	21.8	13.50	12.00
TCHD30S41S3	AHR36B	17.5	-	1060	28.6	21.8	13.50	12.00
TCHD30S41S3	AHV30B	17.5	-	1000	28.2	20.9	14.00	12.25
TCHD30S41S3	AHV36C	21.0	-	895	28.6	20.7	15.00	13.00
TCHD30S41S3	AHV42D	24.5	-	1080	29.6	22.9	15.50	13.25
TCHD30S41S3	MV12B	17.5	FC/MC35B	1000	28.6	21.2	15.00	13.20
TCHD30S41S3	MV12B	17.5	FC/MC43B	1000	29.0	21.6	15.15	13.35
TCHD30S41S3	MV16C	21.0	FC/MC35C	1000	28.6	21.2	15.00	13.25
TCHD30S41S3	MV16C	21.0	FC/MC43C	1000	29.0	21.6	15.35	13.50
TCHD30S41S3	MV16C	21.0	FC/MC48C	1000	29.4	21.8	15.50	13.70
TCHD30S41S3	MX12BN21	17.5	FC/MC35B	975	28.6	21.4	15.00	13.10
TCHD30S41S3	MX12BN21	17.5	FC/MC43B	975	29.0	21.8	15.25	13.30
TCHD30S41S3	MX12DN21	24.5	FC/MC48D	950	29.0	21.6	15.50	13.50
TCHD30S41S3	MX16CN21	21.0	FC/MC35C	1000	28.6	21.4	15.00	13.05
TCHD30S41S3	MX16CN21	21.0	FC/MC43C	950	28.8	21.4	15.75	13.60
TCHD30S41S3	MX16CN21	21.0	FC/MC48C	950	29.0	21.6	15.85	13.75
TCHD30S41S3	MX20DN21	24.5	FC/MC48D	1000	29.0	21.8	14.50	12.75
TCHD36S41S3	AHE36C	21.0	-	1190	34.4	25.4	14.75	12.75
TCHD36S41S3	AHE42D	24.5	-	1180	35.0	25.8	15.50	13.25

For Notes see Page 5

COOLING CAPACITY - With Air Handler Coils (Continued)

UNIT MODEL	AIR HANDLER		COIL MODEL ¹	COOLING				
	MODEL	WIDTH		RATED CFM	NET MBH		SEER	EER
					TOTAL	SENS.		
13 SEER AC WITH AIR HANDLERS								
TCHD36S41S3	AHR36B	17.5	–	1245	33.8	24.6	13.25	11.50
TCHD36S41S3	AHR42C	21.0	–	1230	34.6	25.6	13.75	12.00
TCHD36S41S3	AHV36C	21.0	–	1215	34.4	25.6	14.50	12.00
TCHD36S41S3	AHV42D	24.5	–	1180	35.0	25.8	15.00	12.75
TCHD36S41S3	AHV48D	24.5	–	1155	34.4	25.2	15.00	12.50
TCHD36S41S3	MV12B	17.5	FC/MC43B	1200	34.4	25.2	14.50	12.50
TCHD36S41S3	MV12D	24.5	FC/MC48D	1150	34.6	25.2	15.00	13.00
TCHD36S41S3	MV16C	21.0	FC/MC43C	1200	34.6	25.4	15.00	13.00
TCHD36S41S3	MV16C	21.0	FC/MC48C	1200	35.0	25.6	15.25	13.10
TCHD36S41S3	MX12BN21	17.5	FC/MC35B	1125	33.4	24.1	14.00	11.75
TCHD36S41S3	MX12BN21	17.5	FC/MC43B	1125	33.8	24.5	14.50	12.35
TCHD36S41S3	MX12DN21	24.5	FC/MC48D	1125	34.2	25.1	15.25	13.00
TCHD36S41S3	MX16CN21	21.0	FC/MC35C	1200	33.6	24.7	13.75	11.75
TCHD36S41S3	MX16CN21	21.0	FC/MC43C	1200	34.2	25.3	14.60	12.50
TCHD36S41S3	MX16CN21	21.0	FC/MC48C	1200	34.4	25.7	14.65	12.50
TCHD36S41S3	MX20DN21	24.5	FC/MC48D	1200	34.8	25.9	15.25	12.75
TCHD48S41S3	AHE48D	24.5	–	1600	47.0	34.0	14.00	12.00
TCHD48S41S3	AHE60D	24.5	–	1565	48.0	34.4	14.25	12.25
TCHD48S41S3	AHR48D	24.5	–	1610	47.0	34.0	13.00	11.50
TCHD48S41S3	AHR60D	24.5	–	1620	47.5	34.4	13.25	11.50
TCHD48S41S3	AHV48D	24.5	–	1585	46.5	33.2	13.50	11.50
TCHD48S41S3	AHV60D	24.5	–	1570	47.0	34.0	13.75	11.75
TCHD48S41S3	MV16C	21.0	FC/MC48C	1600	47.5	34.2	14.00	12.10
TCHD48S41S3	MV16C	21.0	FC60C	1625	47.0	33.6	13.75	11.75
TCHD48S41S3	MV20D	24.5	FC/MC48D	1600	47.5	34.2	14.00	12.00
TCHD48S41S3	MV20D	24.5	FC/MC60D	1600	45.5	33.0	13.50	11.60
TCHD48S41S3	MV20D	24.5	FC/MC62D	1600	48.0	34.6	14.25	12.25
TCHD48S41S3	MV20D	24.5	FC64D	1630	49.5	36.0	14.50	12.50
TCHD48S41S3	MX16CN21	21.0	FC/MC48C	1600	46.5	33.5	13.80	11.90
TCHD48S41S3	MX16CN21	21.0	FC60C	1600	46.5	33.3	13.85	11.95
TCHD48S41S3	MX20DN21	24.5	FC/MC48D	1525	46.5	33.1	14.25	12.25
TCHD48S41S3	MX20DN21	24.5	FC/MC60D	1525	47.0	33.5	14.50	12.25
TCHD48S41S3	MX20DN21	24.5	FC/MC62D	1525	47.0	33.7	14.40	12.45
TCHD48S41S3	MX20DN21	24.5	FC64D	1525	48.5	34.7	14.85	12.80
TCHD60S41S3	AHE60D	24.5	–	1835	57.5	40.5	13.50	11.50
TCHD60S41S3	AHV60D	24.5	–	1635	56.5	38.3	13.25	11.00
TCHD60S41S3	MV20D	24.5	FC/MC62D	1800	57.5	39.5	13.40	11.30
TCHD60S41S3	MV20D	24.5	FC64D	1855	59.0	41.5	13.50	11.50
TCHD60S41S3	MX20DN21	24.5	FC/MC62D	1750	57.0	39.2	13.75	11.60
TCHD60S41S3	MX20DN21	24.5	FC64D	1750	58.0	40.6	14.00	11.75

Rated in accordance with DOE test procedures (Federal Register 12-27-79 and 3-18-88) and ANSI/AHRI Standard 210/240.

Cooling MBH based on 80°F entering air temperature, 50% RH (Relative Humidity), and rated air flow.

EER (Energy Efficiency Ratio) is the total cooling output in BTUs at 95°F outdoor ambient divided by the total electric power in watt-hours at those conditions.

SEER (Seasonal Energy Efficiency Ratio) is the total cooling output in BTUs during a normal annual usage period for cooling divided by the total electric power input in watt-hours during the same period.

1. MC coils available with a factory installed horizontal drain pan. See price pages for specific model number.

– = Not applicable.

MA Modular Air Handlers use Coil Only Ratings.

COOLING CAPACITY - Upflow, Downflow & Horizontal Furnaces and Coils (Coil Only Ratings)

UNIT MODEL	COIL		CFM RANGE (MIN.-MAX.)	COOLING				
	MODEL	WIDTH		RATED CFM	NET MBH		SEER ¹	EER
					TOTAL	SENS.		
13 SEER AC COIL ONLY RATINGS								
TCHD18S41S3	FC/MC/PC24	14.5,17.5	450-750	600	18.0	12.6	13.00	11.00
TCHD18S41S3	FC/MC/PC32	14.5	450-750	600	18.1	12.6	13.00	11.05
TCHD18S41S3	FC/MC/PC35	17.5,21.0	450-750	600	18.1	12.6	13.00	11.05
TCHD18S41S3	FC/MC/PC37	14.5	450-750	600	18.4	12.7	13.10	11.25
TCHD18S41S3	HD24	–	450-750	600	18.7	12.9	13.25	11.35
TCHD18S41S3	UC24	14.5,17.5	450-750	600	18.0	12.5	13.00	11.00
TCHD24S41S4	FC/MC/PC24	14.5,17.5	600 - 1000	800	23.4	16.2	13.50	11.50
TCHD24S41S4	FC/MC/PC32	14.5	600 - 1000	800	23.6	16.4	13.50	11.50
TCHD24S41S4	FC/MC/PC35	17.5,21.0	600 - 1000	800	23.6	16.4	13.50	11.50
TCHD24S41S4	FC/MC/PC37	14.5	600 - 1000	800	23.8	16.9	13.75	11.50
TCHD24S41S4	FC/MC/PC43	17.5,21.0	600 - 1000	800	23.8	16.9	13.75	11.50
TCHD24S41S4	FC/MC/PC48	21.0,24.5	600 - 1000	800	24.0	16.8	14.00	11.75
TCHD24S41S4	HD24	–	600 - 1000	800	23.8	16.5	13.75	11.75
TCHD24S41S4	HD36	–	600 - 1000	800	23.2	15.8	13.25	11.25
TCHD24S41S4	UC24	14.5,17.5	600 - 1000	800	23.6	16.4	13.50	11.50
TCHD24S41S4	UC48	21.0,24.5	600 - 1000	800	23.4	16.5	13.75	11.50
TCHD30S41S3	FC/MC/PC32	14.5	800-1200	1000	28.0	20.8	13.50	12.00
TCHD30S41S3	FC/MC/PC35	17.5,21.0	800-1200	1000	28.0	20.8	13.50	12.00
TCHD30S41S3	FC/MC/PC37	14.5	800-1200	1000	28.4	21.2	13.70	12.20
TCHD30S41S3	FC/MC/PC43	17.5,21.0	800-1200	1000	28.4	21.2	13.70	12.20
TCHD30S41S3	FC/MC/PC48	21.0,24.5	800-1200	1000	28.6	21.4	13.75	12.25
TCHD30S41S3	HD36	–	800-1200	1000	27.6	20.0	13.30	11.85
TCHD30S41S3	UC48	21.0,24.5	800-1200	1000	26.8	20.0	13.00	11.50
TCHD36S41S3	FC/MC/PC37	14.5	1000-1400	1200	33.8	24.8	13.50	11.70
TCHD36S41S3	FC/MC/PC43	17.5,21.0	1000-1400	1200	33.8	24.7	13.50	11.70
TCHD36S41S3	FC/MC/PC48	21.0,24.5	1000-1400	1200	34.4	25.2	13.65	12.00
TCHD36S41S3	HD48	–	1000-1400	1200	34.2	25.0	13.65	11.85
TCHD48S41S3	FC/MC/PC48	21.0,24.5	1400-1800	1600	47.0	33.8	13.25	11.50
TCHD48S41S3	FC/MC/PC60	21.0,24.5	1400-1800	1600	46.5	33.2	13.00	11.25
TCHD48S41S3	FC/MC62	24.5	1400-1800	1600	47.5	34.2	13.35	11.60
TCHD48S41S3	FC64	24.5	1400-1800	1600	48.5	35.4	13.50	11.75
TCHD60S41S3	FC/MC62	24.5	1600-2000	1800	57.0	39.5	13.00	11.00
TCHD60S41S3	FC64	24.5	1600-2000	1800	58.5	41.5	13.25	11.25

1. Requires a S1-2FD06700224 Blower Time Delay unless a standard furnace is equipped with one.

MA Modular Air Handlers use Coil Only Ratings.

PSC furnaces, such as the TG8S, TGLS, and TG9S, use Coil Only Ratings.

COOLING CAPACITY - With High Efficiency Motor Furnaces

UNIT MODEL	FURNACE		COIL MODEL 1	COOLING				
	MODEL	WIDTH		RATED CFM	NET MBH		SEER	EER
					TOTAL	SENS.		
13 SEER AC WITH HIGH EFFICIENCY MOTOR FURNACES 2								
TCHD18S41S3	T*(8,L)C*A12	14.5	FC/MC/PC18A	620	18.1	13.9	14.50	12.05
TCHD18S41S3	T*(8,L)C*A12	14.5	FC/MC/PC24A	640	18.5	13.4	14.70	12.20
TCHD18S41S3	T*(8,L)C*A12	14.5	FC/MC/PC32A	590	18.4	13.1	14.55	12.20
TCHD18S41S3	T*(8,L)C*A12	14.5	FC/MC/PC37A	625	18.7	13.5	14.80	12.35
TCHD18S41S3	T*(8,L)C*A12	14.5	HD24	640	19.1	13.8	15.10	12.60
TCHD18S41S3	T*(8,L)C*A12	14.5	HD36	645	18.5	12.9	14.60	12.25
TCHD18S41S3	T*(8,L)C*A12	14.5	UC18A	620	18.2	14.0	14.55	12.10
TCHD18S41S3	T*(8,L)C*A12	14.5	UC24A	640	18.5	13.3	14.75	12.20
TCHD18S41S3	T*(8,L)C*B12	17.5	FC/MC/PC18B	580	17.9	13.7	14.50	12.05
TCHD18S41S3	T*(8,L)C*B12	17.5	FC/MC/PC24B	575	18.4	13.0	15.00	12.40
TCHD18S41S3	T*(8,L)C*B12	17.5	FC/MC/PC35B	650	18.6	13.4	14.70	12.30
TCHD18S41S3	T*(8,L)C*B12	17.5	HD24	575	19.0	13.4	15.30	12.75
TCHD18S41S3	T*(8,L)C*B12	17.5	HD36	650	18.5	12.9	14.70	12.30
TCHD18S41S3	T*(8,L)C*B12	17.5	UC18B	580	18.0	13.8	14.50	12.15
TCHD18S41S3	T*(8,L)C*B12	17.5	UC24B	575	18.4	13.1	15.00	12.45
TCHD18S41S3	T*(8,L)C*C16	21.0	FC/MC/PC35C	600	18.6	13.4	15.05	12.55
TCHD18S41S3	T*(8,L)C*C16	21.0	HD36	595	18.6	12.9	15.00	12.50
TCHD18S41S3	T*(8,L)V*A12	14.5	FC/MC/PC24A	640	18.5	13.4	14.70	12.20
TCHD18S41S3	T*(8,L)V*A12	14.5	FC/MC/PC32A	590	18.4	13.1	14.55	12.20
TCHD18S41S3	T*(8,L)V*A12	14.5	FC/MC/PC37A	625	18.7	13.5	14.80	12.35
TCHD18S41S3	T*(8,L)V*A12	14.5	HD24	640	19.1	13.8	15.10	12.60
TCHD18S41S3	T*(8,L)V*A12	14.5	HD36	645	18.5	12.9	14.60	12.25
TCHD18S41S3	T*(8,L)V*A12	14.5	UC24A	640	18.5	13.3	14.75	12.20
TCHD18S41S3	T*(8,L)V*B12	17.5	FC/MC/PC24B	575	18.4	13.0	15.00	12.40
TCHD18S41S3	T*(8,L)V*B12	17.5	FC/MC/PC35B	650	18.6	13.4	14.70	12.30
TCHD18S41S3	T*(8,L)V*B12	17.5	HD24	575	19.0	13.4	15.30	12.75
TCHD18S41S3	T*(8,L)V*B12	17.5	HD36	650	18.5	12.9	14.70	12.30
TCHD18S41S3	T*(8,L)V*B12	17.5	UC24B	575	18.4	13.1	15.00	12.45
TCHD18S41S3	T*(8,L)V*C16	21.0	FC/MC/PC35C	600	18.6	13.4	15.05	12.55
TCHD18S41S3	T*(8,L)V*C16	21.0	HD36	595	18.6	12.9	15.00	12.50
TCHD18S41S3	T*9(C,V)*B12	17.5	FC/MC/PC24B	610	18.5	13.4	14.85	12.30
TCHD18S41S3	T*9(C,V)*B12	17.5	FC/MC/PC35B	570	18.4	12.9	14.70	12.30
TCHD18S41S3	T*9(C,V)*B12	17.5	HD24	610	19.2	13.9	15.20	12.70
TCHD18S41S3	T*9(C,V)*B12	17.5	HD36	635	18.5	12.9	14.75	12.35
TCHD18S41S3	T*9(C,V)*B12	17.5	UC24B	610	18.5	13.3	14.85	12.40
TCHD18S41S3	T*9(C,V)*C16	21.0	FC/MC/PC35C	645	18.6	13.4	14.85	12.40
TCHD18S41S3	T*9(C,V)*C16	21.0	HD36	595	18.6	12.9	15.00	12.50
TCHD18S41S3	T*9V*A10	14.5	FC/MC/PC18A	580	17.8	12.3	13.75	11.50
TCHD18S41S3	T*9V*A10	14.5	FC/MC/PC24A	575	18.3	12.9	14.25	11.75
TCHD18S41S3	T*9V*A10	14.5	FC/MC/PC32A	580	18.2	12.8	14.25	11.75
TCHD18S41S3	T*9V*A10	14.5	FC/MC/PC37A	570	18.5	12.8	14.50	11.75
TCHD18S41S3	TM8X060A12MP11	14.5	FC/MC/PC18A	600	18.0	12.6	14.00	11.25
TCHD18S41S3	TM8X060A12MP11	14.5	FC/MC/PC24A	600	18.4	13.0	14.60	11.85
TCHD18S41S3	TM8X060A12MP11	14.5	FC/MC/PC32A	600	18.4	13.0	14.55	11.80
TCHD18S41S3	TM8X060A12MP11	14.5	FC/MC/PC37A	600	18.6	13.1	14.50	11.50
TCHD18S41S3	TM8X060A12MP11	14.5	UC18A	600	18.1	12.7	14.00	11.25
TCHD18S41S3	TM8X060A12MP11	14.5	UC24A	600	18.5	13.0	14.60	11.90
TCHD18S41S3	TM8X080B12MP11	17.5	FC/MC/PC18B	600	17.9	12.6	13.75	11.25
TCHD18S41S3	TM8X080B12MP11	17.5	FC/MC/PC24B	600	18.3	12.9	14.50	11.75
TCHD18S41S3	TM8X080B12MP11	17.5	FC/MC/PC35B	600	18.4	13.0	14.00	11.50
TCHD18S41S3	TM8X080B12MP11	17.5	UC18B	600	18.1	12.7	14.00	11.25
TCHD18S41S3	TM8X080B12MP11	17.5	UC24B	600	18.4	12.9	14.50	11.80
TCHD18S41S3	TM8X080C16MP11	21.0	FC/MC/PC35C	600	18.4	13.0	14.00	11.50
TCHD18S41S3	TM8X100C16MP11	21.0	FC/MC/PC35C	600	18.4	13.0	14.00	11.50
TCHD18S41S3	TM9E040A10MP11	14.5	FC/MC/PC18A	600	17.7	12.4	13.35	10.90

For Notes see Page 22

COOLING CAPACITY - With High Efficiency Motor Furnaces (Continued)

UNIT MODEL	FURNACE		COIL MODEL ¹	COOLING				
	MODEL	WIDTH		RATED CFM	NET MBH		SEER	EER
					TOTAL	SENS.		
13 SEER AC WITH HIGH EFFICIENCY MOTOR FURNACES ²								
TCHD18S41S3	TM9E040A10MP11	14.5	FC/MC/PC24A	600	18.1	12.7	13.45	11.00
TCHD18S41S3	TM9E040A10MP11	14.5	FC/MC/PC32A	600	18.1	12.8	13.50	11.05
TCHD18S41S3	TM9E040A10MP11	14.5	FC/MC/PC37A	600	18.3	12.9	13.65	11.15
TCHD18S41S3	TM9E060B12MP11	17.5	FC/MC/PC18B	600	17.9	12.6	13.75	11.00
TCHD18S41S3	TM9E060B12MP11	17.5	FC/MC/PC24B	600	18.3	12.9	14.35	11.65
TCHD18S41S3	TM9E060B12MP11	17.5	FC/MC/PC35B	600	18.3	13.0	14.00	11.25
TCHD18S41S3	TM9E060B12MP11	17.5	UC18B	600	18.1	12.6	13.75	11.25
TCHD18S41S3	TM9E060B12MP11	17.5	UC24B	600	18.4	12.9	14.30	11.70
TCHD18S41S3	TM9E080B12MP11	17.5	FC/MC/PC18B	600	17.9	12.6	13.75	11.00
TCHD18S41S3	TM9E080B12MP11	17.5	FC/MC/PC24B	600	18.3	12.9	14.35	11.65
TCHD18S41S3	TM9E080B12MP11	17.5	FC/MC/PC35B	600	18.3	13.0	14.00	11.25
TCHD18S41S3	TM9E080B12MP11	17.5	UC18B	600	18.1	12.6	13.75	11.25
TCHD18S41S3	TM9E080B12MP11	17.5	UC24B	600	18.4	12.9	14.30	11.70
TCHD18S41S3	TM9E080C16MP11	21.0	FC/MC/PC35C	600	18.4	13.1	14.50	11.75
TCHD18S41S3	TM9E100C16MP11	21.0	FC/MC/PC35C	600	18.4	13.1	14.50	11.75
TCHD18S41S3	TM9X040A10MP11	14.5	FC/MC/PC18A	600	17.7	12.4	13.35	10.90
TCHD18S41S3	TM9X040A10MP11	14.5	FC/MC/PC24A	600	18.1	12.7	13.45	11.00
TCHD18S41S3	TM9X040A10MP11	14.5	FC/MC/PC32A	600	18.1	12.8	13.50	11.05
TCHD18S41S3	TM9X040A10MP11	14.5	FC/MC/PC37A	600	18.3	12.9	13.65	11.15
TCHD18S41S3	TM9X060B12MP11	17.5	FC/MC/PC18B	600	17.9	12.6	13.75	11.00
TCHD18S41S3	TM9X060B12MP11	17.5	FC/MC/PC24B	600	18.3	12.9	14.35	11.65
TCHD18S41S3	TM9X060B12MP11	17.5	FC/MC/PC35B	600	18.3	13.0	14.00	11.25
TCHD18S41S3	TM9X060B12MP11	17.5	UC18B	600	18.1	12.6	13.75	11.25
TCHD18S41S3	TM9X060B12MP11	17.5	UC24B	600	18.4	12.9	14.30	11.70
TCHD18S41S3	TM9X080B12MP11	17.5	FC/MC/PC18B	600	17.9	12.6	13.75	11.00
TCHD18S41S3	TM9X080B12MP11	17.5	FC/MC/PC24B	600	18.3	12.9	14.35	11.65
TCHD18S41S3	TM9X080B12MP11	17.5	FC/MC/PC35B	600	18.3	13.0	14.00	11.25
TCHD18S41S3	TM9X080B12MP11	17.5	UC18B	600	18.1	12.6	13.75	11.25
TCHD18S41S3	TM9X080B12MP11	17.5	UC24B	600	18.4	12.9	14.30	11.70
TCHD18S41S3	TM9X080C16MP11	21.0	FC/MC/PC35C	600	18.4	13.1	14.50	11.75
TCHD18S41S3	TM9X100C16MP11	21.0	FC/MC/PC35C	600	18.4	13.1	14.50	11.75
TCHD18S41S3	TMLX060A12MP11	14.5	FC/MC/PC18A	600	18.0	12.6	14.00	11.25
TCHD18S41S3	TMLX060A12MP11	14.5	FC/MC/PC24A	600	18.4	13.0	14.60	11.85
TCHD18S41S3	TMLX060A12MP11	14.5	FC/MC/PC32A	600	18.4	13.0	14.55	11.80
TCHD18S41S3	TMLX060A12MP11	14.5	FC/MC/PC37A	600	18.6	13.1	14.50	11.50
TCHD18S41S3	TMLX060A12MP11	14.5	UC18A	600	18.1	12.7	14.00	11.25
TCHD18S41S3	TMLX060A12MP11	14.5	UC24A	600	18.5	13.0	14.60	11.90
TCHD18S41S3	TMLX080B12MP11	17.5	FC/MC/PC18B	600	17.9	12.6	13.75	11.25
TCHD18S41S3	TMLX080B12MP11	17.5	FC/MC/PC24B	600	18.3	12.9	14.50	11.75
TCHD18S41S3	TMLX080B12MP11	17.5	FC/MC/PC35B	600	18.4	13.0	14.00	11.50
TCHD18S41S3	TMLX080B12MP11	17.5	UC18B	600	18.1	12.7	14.00	11.25
TCHD18S41S3	TMLX080B12MP11	17.5	UC24B	600	18.4	12.9	14.50	11.80
TCHD18S41S3	TMLX080C16MP11	21.0	FC/MC/PC35C	600	18.4	13.0	14.00	11.50
TCHD18S41S3	TMLX100C16MP11	21.0	FC/MC/PC35C	600	18.4	13.0	14.00	11.50
TCHD18S41S3	Y*(8,L)C*A12	14.5	FC/MC/PC24A	640	18.5	13.4	14.70	12.20
TCHD18S41S3	Y*(8,L)C*A12	14.5	FC/MC/PC32A	590	18.4	13.1	14.55	12.20
TCHD18S41S3	Y*(8,L)C*A12	14.5	FC/MC/PC37A	625	18.7	13.5	14.80	12.35
TCHD18S41S3	Y*(8,L)C*A12	14.5	HD24	640	19.1	13.8	15.10	12.60
TCHD18S41S3	Y*(8,L)C*A12	14.5	HD36	645	18.5	12.9	14.60	12.25
TCHD18S41S3	Y*(8,L)C*A12	14.5	UC24A	640	18.5	13.3	14.75	12.20
TCHD18S41S3	Y*(8,L)C*B12	17.5	FC/MC/PC24B	575	18.4	13.0	15.00	12.40
TCHD18S41S3	Y*(8,L)C*B12	17.5	FC/MC/PC35B	650	18.6	13.4	14.70	12.30
TCHD18S41S3	Y*(8,L)C*B12	17.5	HD24	575	19.0	13.4	15.30	12.75
TCHD18S41S3	Y*(8,L)C*B12	17.5	HD36	650	18.5	12.9	14.70	12.30
TCHD18S41S3	Y*(8,L)C*B12	17.5	UC24B	575	18.4	13.1	15.00	12.45
TCHD18S41S3	Y*(8,L)C*C16	21.0	FC/MC/PC35C	600	18.6	13.4	15.05	12.55

For Notes see Page 22

COOLING CAPACITY - With High Efficiency Motor Furnaces (Continued)

UNIT MODEL	FURNACE		COIL MODEL 1	COOLING				
	MODEL	WIDTH		RATED CFM	NET MBH		SEER	EER
					TOTAL	SENS.		
13 SEER AC WITH HIGH EFFICIENCY MOTOR FURNACES 2								
TCHD18S41S3	Y*(8,L)C*C16	21.0	HD36	595	18.6	12.9	15.00	12.50
TCHD18S41S3	Y*9C*B12	17.5	FC/MC/PC24B	610	18.5	13.4	14.85	12.30
TCHD18S41S3	Y*9C*B12	17.5	FC/MC/PC35B	570	18.4	12.9	14.70	12.30
TCHD18S41S3	Y*9C*B12	17.5	HD24	610	19.2	13.9	15.20	12.70
TCHD18S41S3	Y*9C*B12	17.5	HD36	635	18.5	12.9	14.75	12.35
TCHD18S41S3	Y*9C*B12	17.5	UC24B	610	18.5	13.3	14.85	12.40
TCHD18S41S3	Y*9C*C16	21.0	FC/MC/PC35C	645	18.6	13.4	14.85	12.40
TCHD18S41S3	Y*9C*C16	21.0	HD36	595	18.6	12.9	15.00	12.50
TCHD24S41S4	T*(8,L)C*A12	14.5	FC/MC/PC24A	770	23.8	16.5	15.25	12.75
TCHD24S41S4	T*(8,L)C*A12	14.5	FC/MC/PC32A	755	24.0	16.8	15.50	12.75
TCHD24S41S4	T*(8,L)C*A12	14.5	FC/MC/PC37A	765	24.4	17.3	15.75	13.00
TCHD24S41S4	T*(8,L)C*A12	14.5	HD24	805	24.4	16.9	15.50	13.00
TCHD24S41S4	T*(8,L)C*A12	14.5	HD36	805	23.6	16.2	15.00	12.50
TCHD24S41S4	T*(8,L)C*A12	14.5	UC24A	805	24.2	16.8	15.25	12.75
TCHD24S41S4	T*(8,L)C*B12	17.5	FC/MC/PC24B	760	23.8	16.5	15.25	13.00
TCHD24S41S4	T*(8,L)C*B12	17.5	FC/MC/PC35B	785	24.0	16.8	15.50	13.00
TCHD24S41S4	T*(8,L)C*B12	17.5	FC/MC/PC43B	790	24.4	17.3	15.75	13.00
TCHD24S41S4	T*(8,L)C*B12	17.5	HD24	815	24.4	16.9	15.75	13.25
TCHD24S41S4	T*(8,L)C*B12	17.5	HD36	760	23.4	16.0	15.00	12.50
TCHD24S41S4	T*(8,L)C*B12	17.5	UC24B	815	24.2	16.8	15.50	13.00
TCHD24S41S4	T*(8,L)C*C16	21.0	FC/MC/PC35C	775	24.2	16.9	15.75	13.00
TCHD24S41S4	T*(8,L)C*C16	21.0	FC/MC/PC43C	770	24.4	17.4	16.00	13.25
TCHD24S41S4	T*(8,L)C*C16	21.0	FC/MC/PC48C	770	24.4	17.0	16.00	13.50
TCHD24S41S4	T*(8,L)C*C16	21.0	HD36	855	24.2	16.7	15.50	13.00
TCHD24S41S4	T*(8,L)C*C16	21.0	UC48C	815	24.2	17.0	15.75	13.25
TCHD24S41S4	T*(8,L)C*C20	21.0	FC/MC/PC35C	755	24.2	16.9	15.75	13.25
TCHD24S41S4	T*(8,L)C*C20	21.0	FC/MC/PC43C	740	24.2	16.8	16.00	13.25
TCHD24S41S4	T*(8,L)C*C20	21.0	FC/MC/PC48C	740	24.4	16.9	16.00	13.25
TCHD24S41S4	T*(8,L)C*C20	21.0	HD36	750	23.6	16.0	15.50	13.00
TCHD24S41S4	T*(8,L)C*C20	21.0	UC48C	760	24.0	16.7	15.75	13.00
TCHD24S41S4	T*(8,L)V*A12	14.5	FC/MC/PC24A	770	23.8	16.5	15.25	12.75
TCHD24S41S4	T*(8,L)V*A12	14.5	FC/MC/PC32A	755	24.0	16.8	15.50	12.75
TCHD24S41S4	T*(8,L)V*A12	14.5	FC/MC/PC37A	765	24.4	17.3	15.75	13.00
TCHD24S41S4	T*(8,L)V*A12	14.5	HD24	805	24.4	16.9	15.50	13.00
TCHD24S41S4	T*(8,L)V*A12	14.5	HD36	805	23.6	16.2	15.00	12.50
TCHD24S41S4	T*(8,L)V*A12	14.5	UC24A	805	24.2	16.8	15.25	12.75
TCHD24S41S4	T*(8,L)V*B12	17.5	FC/MC/PC24B	760	23.8	16.5	15.25	13.00
TCHD24S41S4	T*(8,L)V*B12	17.5	FC/MC/PC35B	785	24.0	16.8	15.50	13.00
TCHD24S41S4	T*(8,L)V*B12	17.5	FC/MC/PC43B	790	24.4	17.3	15.75	13.00
TCHD24S41S4	T*(8,L)V*B12	17.5	HD24	815	24.4	16.9	15.75	13.25
TCHD24S41S4	T*(8,L)V*B12	17.5	HD36	760	23.4	16.0	15.00	12.50
TCHD24S41S4	T*(8,L)V*B12	17.5	UC24B	815	24.2	16.8	15.50	13.00
TCHD24S41S4	T*(8,L)V*C16	21.0	FC/MC/PC35C	775	24.2	16.9	15.75	13.00
TCHD24S41S4	T*(8,L)V*C16	21.0	FC/MC/PC43C	770	24.4	17.4	16.00	13.25
TCHD24S41S4	T*(8,L)V*C16	21.0	FC/MC/PC48C	770	24.4	17.0	16.00	13.50
TCHD24S41S4	T*(8,L)V*C16	21.0	HD36	855	24.2	16.7	15.50	13.00
TCHD24S41S4	T*(8,L)V*C16	21.0	UC48C	815	24.2	17.0	15.75	13.25
TCHD24S41S4	T*(8,L)V*C20	21.0	FC/MC/PC35C	755	24.2	16.9	15.75	13.25
TCHD24S41S4	T*(8,L)V*C20	21.0	FC/MC/PC43C	740	24.2	16.8	16.00	13.25
TCHD24S41S4	T*(8,L)V*C20	21.0	FC/MC/PC48C	740	24.4	16.9	16.00	13.25
TCHD24S41S4	T*(8,L)V*C20	21.0	HD36	750	23.6	16.0	15.50	13.00
TCHD24S41S4	T*(8,L)V*C20	21.0	UC48C	760	24.0	16.7	15.75	13.00
TCHD24S41S4	T*9(C,V)*B12	17.5	FC/MC/PC24B	790	24.2	17.0	15.25	12.75
TCHD24S41S4	T*9(C,V)*B12	17.5	FC/MC/PC35B	815	24.0	16.8	15.25	12.75
TCHD24S41S4	T*9(C,V)*B12	17.5	FC/MC/PC43B	800	24.4	17.3	15.50	13.00
TCHD24S41S4	T*9(C,V)*B12	17.5	HD24	790	24.4	16.9	15.50	13.00

For Notes see Page 22

COOLING CAPACITY - With High Efficiency Motor Furnaces (Continued)

UNIT MODEL	FURNACE		COIL MODEL ¹	COOLING				
	MODEL	WIDTH		RATED CFM	NET MBH		SEER	EER
					TOTAL	SENS.		
13 SEER AC WITH HIGH EFFICIENCY MOTOR FURNACES ²								
TCHD24S41S4	T*9(C,V)*B12	17.5	HD36	815	23.6	16.2	15.00	12.50
TCHD24S41S4	T*9(C,V)*B12	17.5	UC24B	790	24.0	16.8	15.25	12.75
TCHD24S41S4	T*9(C,V)*C16	21.0	FC/MC/PC35C	900	24.4	17.9	15.50	13.00
TCHD24S41S4	T*9(C,V)*C16	21.0	FC/MC/PC43C	810	24.4	17.3	15.75	13.00
TCHD24S41S4	T*9(C,V)*C16	21.0	FC/MC/PC48C	890	24.4	17.9	16.00	13.25
TCHD24S41S4	T*9(C,V)*C16	21.0	HD36	785	23.8	16.2	15.25	12.75
TCHD24S41S4	T*9(C,V)*C16	21.0	UC48C	890	24.4	18.1	15.75	13.00
TCHD24S41S4	T*9(C,V)*C20	21.0	FC/MC/PC35C	755	24.2	16.9	15.75	13.00
TCHD24S41S4	T*9(C,V)*C20	21.0	FC/MC/PC43C	890	24.4	18.1	16.00	13.25
TCHD24S41S4	T*9(C,V)*C20	21.0	FC/MC/PC48C	890	24.4	17.9	16.00	13.25
TCHD24S41S4	T*9(C,V)*C20	21.0	HD36	760	23.6	16.1	15.25	12.75
TCHD24S41S4	T*9(C,V)*C20	21.0	UC48C	890	24.4	18.1	15.75	13.00
TCHD24S41S4	T*9V*A10	14.5	FC/MC/PC24A	785	23.6	16.4	14.25	12.00
TCHD24S41S4	T*9V*A10	14.5	FC/MC/PC32A	785	23.8	16.6	14.50	12.25
TCHD24S41S4	T*9V*A10	14.5	FC/MC/PC37A	790	24.0	17.1	14.75	12.25
TCHD24S41S4	TM8X060A12MP11	14.5	FC/MC/PC24A	750	23.6	16.3	15.25	12.75
TCHD24S41S4	TM8X060A12MP11	14.5	FC/MC/PC32A	800	24.0	16.8	15.25	12.75
TCHD24S41S4	TM8X060A12MP11	14.5	FC/MC/PC37A	800	24.2	17.2	15.50	12.75
TCHD24S41S4	TM8X060A12MP11	14.5	HD24	810	24.4	16.9	16.00	13.50
TCHD24S41S4	TM8X060A12MP11	14.5	HD36	815	23.8	16.2	15.25	12.75
TCHD24S41S4	TM8X060A12MP11	14.5	UC24A	750	23.8	16.5	15.25	12.75
TCHD24S41S4	TM8X080B12MP11	17.5	FC/MC/PC24B	775	23.8	16.6	15.25	12.75
TCHD24S41S4	TM8X080B12MP11	17.5	FC/MC/PC35B	750	24.0	16.8	15.50	13.00
TCHD24S41S4	TM8X080B12MP11	17.5	FC/MC/PC43B	775	24.4	17.3	15.75	13.00
TCHD24S41S4	TM8X080B12MP11	17.5	HD24	855	24.4	17.5	16.25	13.50
TCHD24S41S4	TM8X080B12MP11	17.5	HD36	855	24.2	16.8	16.00	13.25
TCHD24S41S4	TM8X080B12MP11	17.5	UC24B	775	24.2	16.8	15.50	13.00
TCHD24S41S4	TM8X080C16MP11	21.0	FC/MC/PC35C	800	23.8	16.7	14.75	12.25
TCHD24S41S4	TM8X080C16MP11	21.0	FC/MC/PC43C	800	24.2	17.1	15.00	12.50
TCHD24S41S4	TM8X080C16MP11	21.0	FC/MC/PC48C	800	24.4	17.1	15.00	12.50
TCHD24S41S4	TM8X080C16MP11	21.0	HD36	855	24.2	16.8	16.00	13.25
TCHD24S41S4	TM8X080C16MP11	21.0	UC48C	800	23.8	16.8	14.75	12.25
TCHD24S41S4	TM8X100C16MP11	21.0	FC/MC/PC35C	800	23.8	16.7	14.75	12.25
TCHD24S41S4	TM8X100C16MP11	21.0	FC/MC/PC43C	800	24.2	17.1	15.00	12.50
TCHD24S41S4	TM8X100C16MP11	21.0	FC/MC/PC48C	800	24.4	17.1	15.00	12.50
TCHD24S41S4	TM8X100C16MP11	21.0	HD36	855	24.2	16.8	16.00	13.25
TCHD24S41S4	TM8X100C16MP11	21.0	UC48C	800	23.8	16.8	14.75	12.25
TCHD24S41S4	TM8X100C20MP11	21.0	FC/MC/PC35C	800	23.8	16.6	14.50	12.00
TCHD24S41S4	TM8X100C20MP11	21.0	FC/MC/PC43C	800	24.0	17.1	14.75	12.25
TCHD24S41S4	TM8X100C20MP11	21.0	FC/MC/PC48C	800	24.4	17.0	14.75	12.50
TCHD24S41S4	TM8X100C20MP11	21.0	HD36	860	24.2	16.9	15.75	13.25
TCHD24S41S4	TM8X100C20MP11	21.0	UC48C	800	23.8	16.7	14.50	12.00
TCHD24S41S4	TM8X120C20MP11	21.0	FC/MC/PC35C	800	23.8	16.6	14.50	12.00
TCHD24S41S4	TM8X120C20MP11	21.0	FC/MC/PC43C	800	24.0	17.1	14.75	12.25
TCHD24S41S4	TM8X120C20MP11	21.0	FC/MC/PC48C	800	24.4	17.0	14.75	12.50
TCHD24S41S4	TM8X120C20MP11	21.0	HD36	860	24.2	16.9	15.75	13.25
TCHD24S41S4	TM8X120C20MP11	21.0	UC48C	800	23.8	16.7	14.50	12.00
TCHD24S41S4	TM9E040A10MP11	14.5	FC/MC/PC24A	800	23.8	16.8	14.00	11.75
TCHD24S41S4	TM9E040A10MP11	14.5	FC/MC/PC32A	775	23.6	16.5	14.00	11.75
TCHD24S41S4	TM9E040A10MP11	14.5	FC/MC/PC37A	800	24.0	17.0	14.50	12.00
TCHD24S41S4	TM9E040A10MP11	14.5	UC24A	800	23.8	16.5	14.00	11.75
TCHD24S41S4	TM9E060B12MP11	17.5	FC/MC/PC24B	800	24.0	16.9	14.75	12.25
TCHD24S41S4	TM9E060B12MP11	17.5	FC/MC/PC35B	800	23.8	16.7	14.75	12.25
TCHD24S41S4	TM9E060B12MP11	17.5	FC/MC/PC43B	800	24.2	17.1	15.00	12.50
TCHD24S41S4	TM9E060B12MP11	17.5	HD24	790	24.4	16.9	16.00	13.50
TCHD24S41S4	TM9E060B12MP11	17.5	HD36	790	23.8	16.3	15.50	13.00

For Notes see Page 22

COOLING CAPACITY - With High Efficiency Motor Furnaces (Continued)

UNIT MODEL	FURNACE		COIL MODEL ¹	COOLING				
	MODEL	WIDTH		RATED CFM	NET MBH		SEER	EER
					TOTAL	SENS.		
13 SEER AC WITH HIGH EFFICIENCY MOTOR FURNACES ²								
TCHD24S41S4	TM9E060B12MP11	17.5	UC24B	800	23.8	16.6	14.50	12.25
TCHD24S41S4	TM9E080B12MP11	17.5	FC/MC/PC24B	800	24.0	16.9	14.75	12.25
TCHD24S41S4	TM9E080B12MP11	17.5	FC/MC/PC35B	800	23.8	16.7	14.75	12.25
TCHD24S41S4	TM9E080B12MP11	17.5	FC/MC/PC43B	800	24.2	17.1	15.00	12.50
TCHD24S41S4	TM9E080B12MP11	17.5	HD24	790	24.4	16.9	16.00	13.50
TCHD24S41S4	TM9E080B12MP11	17.5	HD36	790	23.8	16.3	15.50	13.00
TCHD24S41S4	TM9E080B12MP11	17.5	UC24B	800	23.8	16.6	14.50	12.25
TCHD24S41S4	TM9E080C16MP11	21.0	FC/MC/PC35C	800	23.8	16.6	14.25	12.00
TCHD24S41S4	TM9E080C16MP11	21.0	FC/MC/PC43C	800	24.0	17.0	14.50	12.00
TCHD24S41S4	TM9E080C16MP11	21.0	FC/MC/PC48C	800	24.2	17.0	14.50	12.25
TCHD24S41S4	TM9E080C16MP11	21.0	HD36	730	23.4	15.8	15.25	13.00
TCHD24S41S4	TM9E080C16MP11	21.0	UC48C	800	23.8	16.7	14.25	12.00
TCHD24S41S4	TM9E100C16MP11	21.0	FC/MC/PC35C	800	23.8	16.6	14.25	12.00
TCHD24S41S4	TM9E100C16MP11	21.0	FC/MC/PC43C	800	24.0	17.0	14.50	12.00
TCHD24S41S4	TM9E100C16MP11	21.0	FC/MC/PC48C	800	24.2	17.0	14.50	12.25
TCHD24S41S4	TM9E100C16MP11	21.0	HD36	730	23.4	15.8	15.25	13.00
TCHD24S41S4	TM9E100C16MP11	21.0	UC48C	800	23.8	16.7	14.25	12.00
TCHD24S41S4	TM9E100C20MP11	21.0	FC/MC/PC35C	800	24.0	16.7	15.00	12.50
TCHD24S41S4	TM9E100C20MP11	21.0	FC/MC/PC43C	800	24.2	17.2	15.25	12.75
TCHD24S41S4	TM9E100C20MP11	21.0	FC/MC/PC48C	800	24.4	17.1	15.50	13.00
TCHD24S41S4	TM9E100C20MP11	21.0	HD36	850	24.0	16.7	15.50	13.00
TCHD24S41S4	TM9E100C20MP11	21.0	UC48C	800	24.0	16.9	15.00	12.50
TCHD24S41S4	TM9E120D20MP11	24.5	FC/MC/PC48D	800	24.4	17.1	15.50	13.00
TCHD24S41S4	TM9E120D20MP11	24.5	UC48D	800	24.0	16.9	15.25	12.75
TCHD24S41S4	TM9X040A10MP11	14.5	FC/MC/PC24A	800	23.8	16.8	14.00	11.75
TCHD24S41S4	TM9X040A10MP11	14.5	FC/MC/PC32A	775	23.6	16.5	14.00	11.75
TCHD24S41S4	TM9X040A10MP11	14.5	FC/MC/PC37A	800	24.0	17.0	14.50	12.00
TCHD24S41S4	TM9X040A10MP11	14.5	UC24A	800	23.8	16.5	14.00	11.75
TCHD24S41S4	TM9X060B12MP11	17.5	FC/MC/PC24B	800	24.0	16.9	14.75	12.25
TCHD24S41S4	TM9X060B12MP11	17.5	FC/MC/PC35B	800	23.8	16.7	14.75	12.25
TCHD24S41S4	TM9X060B12MP11	17.5	FC/MC/PC43B	800	24.2	17.1	15.00	12.50
TCHD24S41S4	TM9X060B12MP11	17.5	HD24	790	24.4	16.9	16.00	13.50
TCHD24S41S4	TM9X060B12MP11	17.5	HD36	790	23.8	16.3	15.50	13.00
TCHD24S41S4	TM9X060B12MP11	17.5	UC24B	800	23.8	16.6	14.50	12.25
TCHD24S41S4	TM9X080B12MP11	17.5	FC/MC/PC24B	800	24.0	16.9	14.75	12.25
TCHD24S41S4	TM9X080B12MP11	17.5	FC/MC/PC35B	800	23.8	16.7	14.75	12.25
TCHD24S41S4	TM9X080B12MP11	17.5	FC/MC/PC43B	800	24.2	17.1	15.00	12.50
TCHD24S41S4	TM9X080B12MP11	17.5	HD24	790	24.4	16.9	16.00	13.50
TCHD24S41S4	TM9X080B12MP11	17.5	HD36	790	23.8	16.3	15.50	13.00
TCHD24S41S4	TM9X080B12MP11	17.5	UC24B	800	23.8	16.6	14.50	12.25
TCHD24S41S4	TM9X080C16MP11	21.0	FC/MC/PC35C	800	23.8	16.6	14.25	12.00
TCHD24S41S4	TM9X080C16MP11	21.0	FC/MC/PC43C	800	24.0	17.0	14.50	12.00
TCHD24S41S4	TM9X080C16MP11	21.0	FC/MC/PC48C	800	24.2	17.0	14.50	12.25
TCHD24S41S4	TM9X080C16MP11	21.0	HD36	730	23.4	15.8	15.25	13.00
TCHD24S41S4	TM9X080C16MP11	21.0	UC48C	800	23.8	16.7	14.25	12.00
TCHD24S41S4	TM9X100C16MP11	21.0	FC/MC/PC35C	800	23.8	16.6	14.25	12.00
TCHD24S41S4	TM9X100C16MP11	21.0	FC/MC/PC43C	800	24.0	17.0	14.50	12.00
TCHD24S41S4	TM9X100C16MP11	21.0	FC/MC/PC48C	800	24.2	17.0	14.50	12.25
TCHD24S41S4	TM9X100C16MP11	21.0	HD36	730	23.4	15.8	15.25	13.00
TCHD24S41S4	TM9X100C16MP11	21.0	UC48C	800	23.8	16.7	14.25	12.00
TCHD24S41S4	TM9X100C20MP11	21.0	FC/MC/PC35C	800	24.0	16.7	15.00	12.50
TCHD24S41S4	TM9X100C20MP11	21.0	FC/MC/PC43C	800	24.2	17.2	15.25	12.75
TCHD24S41S4	TM9X100C20MP11	21.0	FC/MC/PC48C	800	24.4	17.1	15.50	13.00
TCHD24S41S4	TM9X100C20MP11	21.0	HD36	850	24.0	16.7	15.50	13.00
TCHD24S41S4	TM9X100C20MP11	21.0	UC48C	800	24.0	16.9	15.00	12.50
TCHD24S41S4	TM9X120D20MP11	24.5	FC/MC/PC48D	800	24.4	17.1	15.50	13.00

For Notes see Page 22

COOLING CAPACITY - With High Efficiency Motor Furnaces (Continued)

UNIT MODEL	FURNACE		COIL MODEL ¹	COOLING				
	MODEL	WIDTH		RATED CFM	NET MBH		SEER	EER
					TOTAL	SENS.		
13 SEER AC WITH HIGH EFFICIENCY MOTOR FURNACES ²								
TCHD24S41S4	TM9X120D20MP11	24.5	UC48D	800	24.0	16.9	15.25	12.75
TCHD24S41S4	TMLX060A12MP11	14.5	FC/MC/PC24A	750	23.6	16.3	15.25	12.75
TCHD24S41S4	TMLX060A12MP11	14.5	FC/MC/PC32A	800	24.0	16.8	15.25	12.75
TCHD24S41S4	TMLX060A12MP11	14.5	FC/MC/PC37A	800	24.2	17.2	15.50	12.75
TCHD24S41S4	TMLX060A12MP11	14.5	HD24	810	24.4	16.9	16.00	13.50
TCHD24S41S4	TMLX060A12MP11	14.5	HD36	815	23.8	16.2	15.25	12.75
TCHD24S41S4	TMLX060A12MP11	14.5	UC24A	750	23.8	16.5	15.25	12.75
TCHD24S41S4	TMLX080B12MP11	17.5	FC/MC/PC24B	775	23.8	16.6	15.25	12.75
TCHD24S41S4	TMLX080B12MP11	17.5	FC/MC/PC35B	750	24.0	16.8	15.50	13.00
TCHD24S41S4	TMLX080B12MP11	17.5	FC/MC/PC43B	775	24.4	17.3	15.75	13.00
TCHD24S41S4	TMLX080B12MP11	17.5	HD24	855	24.4	17.5	16.25	13.50
TCHD24S41S4	TMLX080B12MP11	17.5	HD36	855	24.2	16.8	16.00	13.25
TCHD24S41S4	TMLX080B12MP11	17.5	UC24B	775	24.2	16.8	15.50	13.00
TCHD24S41S4	TMLX080C16MP11	21.0	FC/MC/PC35C	800	23.8	16.7	14.75	12.25
TCHD24S41S4	TMLX080C16MP11	21.0	FC/MC/PC43C	800	24.2	17.1	15.00	12.50
TCHD24S41S4	TMLX080C16MP11	21.0	FC/MC/PC48C	800	24.4	17.1	15.00	12.50
TCHD24S41S4	TMLX080C16MP11	21.0	HD36	855	24.2	16.8	16.00	13.25
TCHD24S41S4	TMLX080C16MP11	21.0	UC48C	800	23.8	16.8	14.75	12.25
TCHD24S41S4	TMLX100C16MP11	21.0	FC/MC/PC35C	800	23.8	16.7	14.75	12.25
TCHD24S41S4	TMLX100C16MP11	21.0	FC/MC/PC43C	800	24.2	17.1	15.00	12.50
TCHD24S41S4	TMLX100C16MP11	21.0	FC/MC/PC48C	800	24.4	17.1	15.00	12.50
TCHD24S41S4	TMLX100C16MP11	21.0	HD36	855	24.2	16.8	16.00	13.25
TCHD24S41S4	TMLX100C16MP11	21.0	UC48C	800	23.8	16.8	14.75	12.25
TCHD24S41S4	TMLX100C20MP11	21.0	FC/MC/PC35C	800	23.8	16.6	14.50	12.00
TCHD24S41S4	TMLX100C20MP11	21.0	FC/MC/PC43C	800	24.0	17.1	14.75	12.25
TCHD24S41S4	TMLX100C20MP11	21.0	FC/MC/PC48C	800	24.4	17.0	14.75	12.50
TCHD24S41S4	TMLX100C20MP11	21.0	HD36	860	24.2	16.9	15.75	13.25
TCHD24S41S4	TMLX100C20MP11	21.0	UC48C	800	23.8	16.7	14.50	12.00
TCHD24S41S4	TMLX120C20MP11	21.0	FC/MC/PC35C	800	23.8	16.6	14.50	12.00
TCHD24S41S4	TMLX120C20MP11	21.0	FC/MC/PC43C	800	24.0	17.1	14.75	12.25
TCHD24S41S4	TMLX120C20MP11	21.0	FC/MC/PC48C	800	24.4	17.0	14.75	12.50
TCHD24S41S4	TMLX120C20MP11	21.0	HD36	860	24.2	16.9	15.75	13.25
TCHD24S41S4	TMLX120C20MP11	21.0	UC48C	800	23.8	16.7	14.50	12.00
TCHD24S41S4	Y*(8,L)C*A12	14.5	FC/MC/PC24A	770	23.8	16.5	15.25	12.75
TCHD24S41S4	Y*(8,L)C*A12	14.5	FC/MC/PC32A	755	24.0	16.8	15.50	12.75
TCHD24S41S4	Y*(8,L)C*A12	14.5	FC/MC/PC37A	765	24.4	17.3	15.75	13.00
TCHD24S41S4	Y*(8,L)C*A12	14.5	HD24	805	24.4	16.9	15.50	13.00
TCHD24S41S4	Y*(8,L)C*A12	14.5	HD36	805	23.6	16.2	15.00	12.50
TCHD24S41S4	Y*(8,L)C*A12	14.5	UC24A	805	24.2	16.8	15.25	12.75
TCHD24S41S4	Y*(8,L)C*B12	17.5	FC/MC/PC24B	760	23.8	16.5	15.25	13.00
TCHD24S41S4	Y*(8,L)C*B12	17.5	FC/MC/PC35B	785	24.0	16.8	15.50	13.00
TCHD24S41S4	Y*(8,L)C*B12	17.5	FC/MC/PC43B	790	24.4	17.3	15.75	13.00
TCHD24S41S4	Y*(8,L)C*B12	17.5	HD24	815	24.4	16.9	15.75	13.25
TCHD24S41S4	Y*(8,L)C*B12	17.5	HD36	760	23.4	16.0	15.00	12.50
TCHD24S41S4	Y*(8,L)C*B12	17.5	UC24B	815	24.2	16.8	15.50	13.00
TCHD24S41S4	Y*(8,L)C*C16	21.0	FC/MC/PC35C	775	24.2	16.9	15.75	13.00
TCHD24S41S4	Y*(8,L)C*C16	21.0	FC/MC/PC43C	770	24.4	17.4	16.00	13.25
TCHD24S41S4	Y*(8,L)C*C16	21.0	FC/MC/PC48C	770	24.4	17.0	16.00	13.50
TCHD24S41S4	Y*(8,L)C*C16	21.0	HD36	855	24.2	16.7	15.50	13.00
TCHD24S41S4	Y*(8,L)C*C16	21.0	UC48C	815	24.2	17.0	15.75	13.25
TCHD24S41S4	Y*(8,L)C*C20	21.0	FC/MC/PC35C	755	24.2	16.9	15.75	13.25
TCHD24S41S4	Y*(8,L)C*C20	21.0	FC/MC/PC43C	740	24.2	16.8	16.00	13.25
TCHD24S41S4	Y*(8,L)C*C20	21.0	FC/MC/PC48C	740	24.4	16.9	16.00	13.25
TCHD24S41S4	Y*(8,L)C*C20	21.0	HD36	750	23.6	16.0	15.50	13.00
TCHD24S41S4	Y*(8,L)C*C20	21.0	UC48C	760	24.0	16.7	15.75	13.00
TCHD24S41S4	Y*9C*B12	17.5	FC/MC/PC24B	790	24.2	17.0	15.25	12.75

For Notes see Page 22

COOLING CAPACITY - With High Efficiency Motor Furnaces (Continued)

UNIT MODEL	FURNACE		COIL MODEL 1	COOLING				
	MODEL	WIDTH		RATED CFM	NET MBH		SEER	EER
					TOTAL	SENS.		
13 SEER AC WITH HIGH EFFICIENCY MOTOR FURNACES 2								
TCHD24S41S4	Y*9C*B12	17.5	FC/MC/PC35B	815	24.0	16.8	15.25	12.75
TCHD24S41S4	Y*9C*B12	17.5	FC/MC/PC43B	800	24.4	17.3	15.50	13.00
TCHD24S41S4	Y*9C*B12	17.5	HD24	790	24.4	16.9	15.50	13.00
TCHD24S41S4	Y*9C*B12	17.5	HD36	815	23.6	16.2	15.00	12.50
TCHD24S41S4	Y*9C*B12	17.5	UC24B	790	24.0	16.8	15.25	12.75
TCHD24S41S4	Y*9C*C16	21.0	FC/MC/PC35C	900	24.4	17.9	15.50	13.00
TCHD24S41S4	Y*9C*C16	21.0	FC/MC/PC43C	810	24.4	17.3	15.75	13.00
TCHD24S41S4	Y*9C*C16	21.0	FC/MC/PC48C	890	24.4	17.9	16.00	13.25
TCHD24S41S4	Y*9C*C16	21.0	HD36	785	23.8	16.2	15.25	12.75
TCHD24S41S4	Y*9C*C16	21.0	UC48C	890	24.4	18.1	15.75	13.00
TCHD24S41S4	Y*9C*C20	21.0	FC/MC/PC35C	755	24.2	16.9	15.75	13.00
TCHD24S41S4	Y*9C*C20	21.0	FC/MC/PC43C	890	24.4	18.1	16.00	13.25
TCHD24S41S4	Y*9C*C20	21.0	FC/MC/PC48C	890	24.4	17.9	16.00	13.25
TCHD24S41S4	Y*9C*C20	21.0	HD36	760	23.6	16.1	15.25	12.75
TCHD24S41S4	Y*9C*C20	21.0	UC48C	890	24.4	18.1	15.75	13.00
TCHD30S41S3	T*(8,L)C*A12	14.5	FC/MC/PC32A	1045	28.0	21.0	13.65	12.10
TCHD30S41S3	T*(8,L)C*A12	14.5	FC/MC/PC37A	980	28.8	21.6	14.50	12.80
TCHD30S41S3	T*(8,L)C*A12	14.5	HD36	1000	28.0	20.2	14.30	12.65
TCHD30S41S3	T*(8,L)C*B12	17.5	FC/MC/PC35B	995	28.4	21.2	14.50	12.75
TCHD30S41S3	T*(8,L)C*B12	17.5	FC/MC/PC43B	990	28.8	21.8	15.00	13.20
TCHD30S41S3	T*(8,L)C*B12	17.5	HD36	985	28.0	20.4	14.65	13.00
TCHD30S41S3	T*(8,L)C*C16	21.0	FC/MC/PC35C	1025	28.4	21.4	15.00	13.15
TCHD30S41S3	T*(8,L)C*C16	21.0	FC/MC/PC43C	990	29.0	21.8	15.35	13.60
TCHD30S41S3	T*(8,L)C*C16	21.0	HD36	1020	28.2	20.4	14.80	13.05
TCHD30S41S3	T*(8,L)C*C20	21.0	FC/MC/PC35C	1080	28.8	22.2	15.00	13.00
TCHD30S41S3	T*(8,L)C*C20	21.0	FC/MC/PC43C	1000	29.0	21.8	15.40	13.65
TCHD30S41S3	T*(8,L)C*C20	21.0	HD36	1055	28.4	21.0	15.00	13.25
TCHD30S41S3	T*(8,L)V*A12	14.5	FC/MC/PC32A	1045	28.0	21.0	13.65	12.10
TCHD30S41S3	T*(8,L)V*A12	14.5	FC/MC/PC37A	980	28.8	21.6	14.50	12.80
TCHD30S41S3	T*(8,L)V*A12	14.5	HD36	1000	28.0	20.2	14.30	12.65
TCHD30S41S3	T*(8,L)V*B12	17.5	FC/MC/PC35B	995	28.4	21.2	14.50	12.75
TCHD30S41S3	T*(8,L)V*B12	17.5	FC/MC/PC43B	990	28.8	21.8	15.00	13.20
TCHD30S41S3	T*(8,L)V*B12	17.5	HD36	985	28.0	20.4	14.65	13.00
TCHD30S41S3	T*(8,L)V*C16	21.0	FC/MC/PC35C	1025	28.4	21.4	15.00	13.15
TCHD30S41S3	T*(8,L)V*C16	21.0	FC/MC/PC43C	990	29.0	21.8	15.35	13.60
TCHD30S41S3	T*(8,L)V*C16	21.0	HD36	1020	28.2	20.4	14.80	13.05
TCHD30S41S3	T*(8,L)V*C20	21.0	FC/MC/PC35C	1080	28.8	22.2	15.00	13.00
TCHD30S41S3	T*(8,L)V*C20	21.0	FC/MC/PC43C	1000	29.0	21.8	15.40	13.65
TCHD30S41S3	T*(8,L)V*C20	21.0	HD36	1055	28.4	21.0	15.00	13.25
TCHD30S41S3	T*9(C,V)*B12	17.5	FC/MC/PC35B	1045	28.2	21.6	14.25	12.50
TCHD30S41S3	T*9(C,V)*B12	17.5	FC/MC/PC43B	1035	28.8	21.6	14.50	12.85
TCHD30S41S3	T*9(C,V)*B12	17.5	HD36	985	28.0	20.4	14.60	12.85
TCHD30S41S3	T*9(C,V)*C16	21.0	FC/MC/PC35C	1005	28.4	21.4	15.00	13.10
TCHD30S41S3	T*9(C,V)*C16	21.0	FC/MC/PC43C	1030	28.8	21.6	14.80	13.15
TCHD30S41S3	T*9(C,V)*C16	21.0	HD36	1005	28.2	20.4	14.85	13.05
TCHD30S41S3	T*9(C,V)*C20	21.0	FC/MC/PC35C	985	28.4	21.4	15.00	13.10
TCHD30S41S3	T*9(C,V)*C20	21.0	FC/MC/PC43C	995	29.0	21.8	15.20	13.45
TCHD30S41S3	T*9(C,V)*C20	21.0	HD36	1045	28.0	20.4	14.65	13.00
TCHD30S41S3	TM8X060A12MP11	14.5	FC/MC/PC32A	1025	28.0	21.0	13.55	11.95
TCHD30S41S3	TM8X060A12MP11	14.5	FC/MC/PC37A	1025	28.4	21.4	13.80	12.15
TCHD30S41S3	TM8X080B12MP11	17.5	FC/MC/PC35B	950	28.2	20.8	14.50	12.75
TCHD30S41S3	TM8X080B12MP11	17.5	FC/MC/PC43B	975	29.0	21.8	14.75	12.75
TCHD30S41S3	TM8X080C16MP11	21.0	FC/MC/PC35C	975	28.8	21.6	15.00	13.00
TCHD30S41S3	TM8X080C16MP11	21.0	FC/MC/PC43C	950	28.6	21.4	15.00	13.00
TCHD30S41S3	TM8X080C16MP11	21.0	FC/MC/PC48C	975	28.8	21.4	15.00	13.00
TCHD30S41S3	TM8X080C16MP11	21.0	FC/MC/PC48D	975	28.8	21.4	15.00	13.00

For Notes see Page 22

COOLING CAPACITY - With High Efficiency Motor Furnaces (Continued)

UNIT MODEL	FURNACE		COIL MODEL ¹	COOLING				
	MODEL	WIDTH		RATED CFM	NET MBH		SEER	EER
					TOTAL	SENS.		
13 SEER AC WITH HIGH EFFICIENCY MOTOR FURNACES ²								
TCHD30S41S3	TM8X080C16MP11	21.0	UC48C	975	28.6	21.6	14.75	13.00
TCHD30S41S3	TM8X080C16MP11	21.0	UC48D	975	28.6	21.6	15.00	13.00
TCHD30S41S3	TM8X100C16MP11	21.0	FC/MC/PC35C	975	28.8	21.6	15.00	13.00
TCHD30S41S3	TM8X100C16MP11	21.0	FC/MC/PC43C	950	28.6	21.4	15.00	13.00
TCHD30S41S3	TM8X100C16MP11	21.0	FC/MC/PC48C	975	28.8	21.4	15.00	13.00
TCHD30S41S3	TM8X100C16MP11	21.0	FC/MC/PC48D	975	28.8	21.4	15.00	13.00
TCHD30S41S3	TM8X100C16MP11	21.0	UC48C	975	28.6	21.6	14.75	13.00
TCHD30S41S3	TM8X100C16MP11	21.0	UC48D	975	28.6	21.6	15.00	13.00
TCHD30S41S3	TM8X100C20MP11	21.0	FC/MC/PC35C	1000	28.6	21.6	14.75	13.00
TCHD30S41S3	TM8X100C20MP11	21.0	FC/MC/PC43C	1000	29.0	22.0	15.00	13.00
TCHD30S41S3	TM8X100C20MP11	21.0	FC/MC/PC48C	1000	29.2	21.8	15.35	13.40
TCHD30S41S3	TM8X100C20MP11	21.0	FC/MC/PC48D	1000	29.0	21.8	15.00	13.00
TCHD30S41S3	TM8X100C20MP11	21.0	UC48C	1000	28.4	21.4	14.75	12.75
TCHD30S41S3	TM8X100C20MP11	21.0	UC48D	1000	28.4	21.4	14.75	12.75
TCHD30S41S3	TM8X100C20MP11	21.0	UC48D	1000	28.4	21.4	14.75	12.75
TCHD30S41S3	TM8X120C20MP11	21.0	FC/MC/PC35C	1000	28.6	21.6	14.75	13.00
TCHD30S41S3	TM8X120C20MP11	21.0	FC/MC/PC43C	1000	29.0	22.0	15.00	13.00
TCHD30S41S3	TM8X120C20MP11	21.0	FC/MC/PC48C	1000	29.2	21.8	15.35	13.40
TCHD30S41S3	TM8X120C20MP11	21.0	FC/MC/PC48D	1000	29.0	21.8	15.00	13.00
TCHD30S41S3	TM8X120C20MP11	21.0	UC48C	1000	28.4	21.4	14.75	12.75
TCHD30S41S3	TM8X120C20MP11	21.0	UC48D	1000	28.4	21.4	14.75	12.75
TCHD30S41S3	TM9E060B12MP11	17.5	FC/MC/PC35B	950	28.0	20.8	14.25	12.65
TCHD30S41S3	TM9E060B12MP11	17.5	FC/MC/PC43B	950	28.4	21.2	14.50	12.50
TCHD30S41S3	TM9E080B12MP11	17.5	FC/MC/PC35B	950	28.0	20.8	14.25	12.65
TCHD30S41S3	TM9E080B12MP11	17.5	FC/MC/PC43B	950	28.4	21.2	14.50	12.50
TCHD30S41S3	TM9E080C16MP11	21.0	FC/MC/PC35C	1000	28.6	21.6	14.75	13.00
TCHD30S41S3	TM9E080C16MP11	21.0	FC/MC/PC43C	1000	29.0	21.8	15.00	13.00
TCHD30S41S3	TM9E080C16MP11	21.0	FC/MC/PC48C	1000	29.0	21.8	15.25	13.25
TCHD30S41S3	TM9E080C16MP11	21.0	FC/MC/PC48D	1000	29.0	21.8	15.00	13.00
TCHD30S41S3	TM9E080C16MP11	21.0	UC48C	1000	28.4	21.4	14.50	12.75
TCHD30S41S3	TM9E080C16MP11	21.0	UC48D	1000	28.4	21.4	14.50	12.75
TCHD30S41S3	TM9E100C16MP11	21.0	FC/MC/PC35C	1000	28.6	21.6	14.75	13.00
TCHD30S41S3	TM9E100C16MP11	21.0	FC/MC/PC43C	1000	29.0	21.8	15.00	13.00
TCHD30S41S3	TM9E100C16MP11	21.0	FC/MC/PC48C	1000	29.0	21.8	15.25	13.25
TCHD30S41S3	TM9E100C16MP11	21.0	FC/MC/PC48D	1000	29.0	21.8	15.00	13.00
TCHD30S41S3	TM9E100C16MP11	21.0	UC48C	1000	28.4	21.4	14.50	12.75
TCHD30S41S3	TM9E100C16MP11	21.0	UC48D	1000	28.4	21.4	14.50	12.75
TCHD30S41S3	TM9E100C20MP11	21.0	FC/MC/PC35C	1000	28.4	21.2	13.75	12.00
TCHD30S41S3	TM9E100C20MP11	21.0	FC/MC/PC43C	1000	28.6	21.6	14.00	12.25
TCHD30S41S3	TM9E100C20MP11	21.0	FC/MC/PC48C	1000	28.6	21.4	13.75	12.25
TCHD30S41S3	TM9E100C20MP11	21.0	FC/MC/PC48D	1000	28.8	21.4	14.00	12.25
TCHD30S41S3	TM9E100C20MP11	21.0	UC48C	1000	28.0	21.2	13.75	12.00
TCHD30S41S3	TM9E100C20MP11	21.0	UC48D	1000	28.2	21.2	13.75	12.00
TCHD30S41S3	TM9E120D20MP11	24.5	FC/MC/PC48D	1000	28.8	21.6	14.00	12.25
TCHD30S41S3	TM9E120D20MP11	24.5	UC48D	1000	28.2	21.2	13.75	12.00
TCHD30S41S3	TM9X060B12MP11	17.5	FC/MC/PC35B	950	28.0	20.8	14.25	12.65
TCHD30S41S3	TM9X060B12MP11	17.5	FC/MC/PC43B	950	28.4	21.2	14.50	12.50
TCHD30S41S3	TM9X080B12MP11	17.5	FC/MC/PC35B	950	28.0	20.8	14.25	12.65
TCHD30S41S3	TM9X080B12MP11	17.5	FC/MC/PC43B	950	28.4	21.2	14.50	12.50
TCHD30S41S3	TM9X080C16MP11	21.0	FC/MC/PC35C	1000	28.6	21.6	14.75	13.00
TCHD30S41S3	TM9X080C16MP11	21.0	FC/MC/PC43C	1000	29.0	21.8	15.00	13.00
TCHD30S41S3	TM9X080C16MP11	21.0	FC/MC/PC48C	1000	29.0	21.8	15.25	13.25
TCHD30S41S3	TM9X080C16MP11	21.0	FC/MC/PC48D	1000	29.0	21.8	15.00	13.00
TCHD30S41S3	TM9X080C16MP11	21.0	UC48C	1000	28.4	21.4	14.50	12.75
TCHD30S41S3	TM9X080C16MP11	21.0	UC48D	1000	28.4	21.4	14.50	12.75
TCHD30S41S3	TM9X100C16MP11	21.0	FC/MC/PC35C	1000	28.6	21.6	14.75	13.00
TCHD30S41S3	TM9X100C16MP11	21.0	FC/MC/PC43C	1000	29.0	21.8	15.00	13.00

For Notes see Page 22

COOLING CAPACITY - With High Efficiency Motor Furnaces (Continued)

UNIT MODEL	FURNACE		COIL MODEL ¹	COOLING				
	MODEL	WIDTH		RATED CFM	NET MBH		SEER	EER
					TOTAL	SENS.		
13 SEER AC WITH HIGH EFFICIENCY MOTOR FURNACES ²								
TCHD30S41S3	TM9X100C16MP11	21.0	FC/MC/PC48C	1000	29.0	21.8	15.25	13.25
TCHD30S41S3	TM9X100C16MP11	21.0	FC/MC/PC48D	1000	29.0	21.8	15.00	13.00
TCHD30S41S3	TM9X100C16MP11	21.0	UC48C	1000	28.4	21.4	14.50	12.75
TCHD30S41S3	TM9X100C16MP11	21.0	UC48D	1000	28.4	21.4	14.50	12.75
TCHD30S41S3	TM9X100C20MP11	21.0	FC/MC/PC35C	1000	28.4	21.2	13.75	12.00
TCHD30S41S3	TM9X100C20MP11	21.0	FC/MC/PC43C	1000	28.6	21.6	14.00	12.25
TCHD30S41S3	TM9X100C20MP11	21.0	FC/MC/PC48C	1000	28.6	21.4	13.75	12.25
TCHD30S41S3	TM9X100C20MP11	21.0	FC/MC/PC48D	1000	28.8	21.4	14.00	12.25
TCHD30S41S3	TM9X100C20MP11	21.0	UC48C	1000	28.0	21.2	13.75	12.00
TCHD30S41S3	TM9X100C20MP11	21.0	UC48D	1000	28.2	21.2	13.75	12.00
TCHD30S41S3	TM9X120D20MP11	24.5	FC/MC/PC48D	1000	28.8	21.6	14.00	12.25
TCHD30S41S3	TM9X120D20MP11	24.5	UC48D	1000	28.2	21.2	13.75	12.00
TCHD30S41S3	TMLX060A12MP11	14.5	FC/MC/PC32A	1025	28.0	21.0	13.55	11.95
TCHD30S41S3	TMLX060A12MP11	14.5	FC/MC/PC37A	1025	28.4	21.4	13.80	12.15
TCHD30S41S3	TMLX080B12MP11	17.5	FC/MC/PC35B	950	28.2	20.8	14.50	12.75
TCHD30S41S3	TMLX080B12MP11	17.5	FC/MC/PC43B	975	29.0	21.8	14.75	12.75
TCHD30S41S3	TMLX080C16MP11	21.0	FC/MC/PC35C	975	28.8	21.6	15.00	13.00
TCHD30S41S3	TMLX080C16MP11	21.0	FC/MC/PC43C	950	28.6	21.4	15.00	13.00
TCHD30S41S3	TMLX080C16MP11	21.0	FC/MC/PC48C	975	28.8	21.4	15.00	13.00
TCHD30S41S3	TMLX080C16MP11	21.0	FC/MC/PC48D	975	28.8	21.4	15.00	13.00
TCHD30S41S3	TMLX080C16MP11	21.0	UC48C	975	28.6	21.6	14.75	13.00
TCHD30S41S3	TMLX080C16MP11	21.0	UC48D	975	28.6	21.6	15.00	13.00
TCHD30S41S3	TMLX100C16MP11	21.0	FC/MC/PC35C	975	28.8	21.6	15.00	13.00
TCHD30S41S3	TMLX100C16MP11	21.0	FC/MC/PC43C	950	28.6	21.4	15.00	13.00
TCHD30S41S3	TMLX100C16MP11	21.0	FC/MC/PC48C	975	28.8	21.4	15.00	13.00
TCHD30S41S3	TMLX100C16MP11	21.0	FC/MC/PC48D	975	28.8	21.4	15.00	13.00
TCHD30S41S3	TMLX100C16MP11	21.0	UC48C	975	28.6	21.6	14.75	13.00
TCHD30S41S3	TMLX100C16MP11	21.0	UC48D	975	28.6	21.6	15.00	13.00
TCHD30S41S3	TMLX100C20MP11	21.0	FC/MC/PC35C	1000	28.6	21.6	14.75	13.00
TCHD30S41S3	TMLX100C20MP11	21.0	FC/MC/PC43C	1000	29.0	22.0	15.00	13.00
TCHD30S41S3	TMLX100C20MP11	21.0	FC/MC/PC48C	1000	29.2	21.8	15.35	13.40
TCHD30S41S3	TMLX100C20MP11	21.0	FC/MC/PC48D	1000	29.0	21.8	15.00	13.00
TCHD30S41S3	TMLX100C20MP11	21.0	UC48C	1000	28.4	21.4	14.75	12.75
TCHD30S41S3	TMLX100C20MP11	21.0	UC48D	1000	28.4	21.4	14.75	12.75
TCHD30S41S3	TMLX120C20MP11	21.0	FC/MC/PC35C	1000	28.6	21.6	14.75	13.00
TCHD30S41S3	TMLX120C20MP11	21.0	FC/MC/PC43C	1000	29.0	22.0	15.00	13.00
TCHD30S41S3	TMLX120C20MP11	21.0	FC/MC/PC48C	1000	29.2	21.8	15.35	13.40
TCHD30S41S3	TMLX120C20MP11	21.0	FC/MC/PC48D	1000	29.0	21.8	15.00	13.00
TCHD30S41S3	TMLX120C20MP11	21.0	UC48C	1000	28.4	21.4	14.75	12.75
TCHD30S41S3	TMLX120C20MP11	21.0	UC48D	1000	28.4	21.4	14.75	12.75
TCHD30S41S3	Y*(8,L)C*A12	14.5	FC/MC/PC32A	1045	28.0	21.0	13.65	12.10
TCHD30S41S3	Y*(8,L)C*A12	14.5	FC/MC/PC37A	980	28.8	21.6	14.50	12.80
TCHD30S41S3	Y*(8,L)C*A12	14.5	HD36	1000	28.0	20.2	14.30	12.65
TCHD30S41S3	Y*(8,L)C*B12	17.5	FC/MC/PC35B	995	28.4	21.2	14.50	12.75
TCHD30S41S3	Y*(8,L)C*B12	17.5	FC/MC/PC43B	990	28.8	21.8	15.00	13.20
TCHD30S41S3	Y*(8,L)C*B12	17.5	HD36	985	28.0	20.4	14.65	13.00
TCHD30S41S3	Y*(8,L)C*C16	21.0	FC/MC/PC35C	1025	28.4	21.4	15.00	13.15
TCHD30S41S3	Y*(8,L)C*C16	21.0	FC/MC/PC43C	990	29.0	21.8	15.35	13.60
TCHD30S41S3	Y*(8,L)C*C16	21.0	HD36	1020	28.2	20.4	14.80	13.05
TCHD30S41S3	Y*(8,L)C*C20	21.0	FC/MC/PC35C	1080	28.8	22.2	15.00	13.00
TCHD30S41S3	Y*(8,L)C*C20	21.0	FC/MC/PC43C	1000	29.0	21.8	15.40	13.65
TCHD30S41S3	Y*(8,L)C*C20	21.0	HD36	1055	28.4	21.0	15.00	13.25
TCHD30S41S3	Y*9C*B12	17.5	FC/MC/PC35B	1045	28.2	21.6	14.25	12.50
TCHD30S41S3	Y*9C*B12	17.5	FC/MC/PC43B	1035	28.8	21.6	14.50	12.85
TCHD30S41S3	Y*9C*B12	17.5	HD36	985	28.0	20.4	14.60	12.85
TCHD30S41S3	Y*9C*C16	21.0	FC/MC/PC35C	1005	28.4	21.4	15.00	13.10

For Notes see Page 22

COOLING CAPACITY - With High Efficiency Motor Furnaces (Continued)

UNIT MODEL	FURNACE		COIL MODEL ¹	COOLING				
	MODEL	WIDTH		RATED CFM	NET MBH		SEER	EER
					TOTAL	SENS.		
13 SEER AC WITH HIGH EFFICIENCY MOTOR FURNACES ²								
TCHD30S41S3	Y*9C*C16	21.0	FC/MC/PC43C	1030	28.8	21.6	14.80	13.15
TCHD30S41S3	Y*9C*C16	21.0	HD36	1005	28.2	20.4	14.85	13.05
TCHD30S41S3	Y*9C*C20	21.0	FC/MC/PC35C	985	28.4	21.4	15.00	13.10
TCHD30S41S3	Y*9C*C20	21.0	FC/MC/PC43C	995	29.0	21.8	15.20	13.45
TCHD30S41S3	Y*9C*C20	21.0	HD36	1045	28.0	20.4	14.65	13.00
TCHD36S41S3	T*(8,L)C*A12	14.5	FC/MC/PC32A	1045	32.6	23.7	13.45	11.70
TCHD36S41S3	T*(8,L)C*A12	14.5	FC/MC/PC37A	980	33.0	23.0	13.95	12.00
TCHD36S41S3	T*(8,L)C*A12	14.5	HD36	1190	33.2	23.2	13.40	11.70
TCHD36S41S3	T*(8,L)C*B12	17.5	FC/MC/PC35B	1220	33.4	23.4	13.55	11.75
TCHD36S41S3	T*(8,L)C*B12	17.5	FC/MC/PC43B	1210	34.2	25.2	13.95	12.00
TCHD36S41S3	T*(8,L)C*B12	17.5	HD36	1220	33.2	23.2	13.70	12.00
TCHD36S41S3	T*(8,L)C*B12	17.5	HD48	1210	34.6	25.2	14.50	12.45
TCHD36S41S3	T*(8,L)C*C16	21.0	FC/MC/PC35C	1235	33.6	23.6	14.20	12.30
TCHD36S41S3	T*(8,L)C*C16	21.0	FC/MC/PC43C	1205	34.4	25.4	14.60	12.50
TCHD36S41S3	T*(8,L)C*C16	21.0	FC/MC/PC48C	1210	35.0	26.0	15.10	13.00
TCHD36S41S3	T*(8,L)C*C16	21.0	HD36	1235	33.4	23.4	14.15	12.30
TCHD36S41S3	T*(8,L)C*C16	21.0	HD48	1210	34.8	25.4	15.00	13.00
TCHD36S41S3	T*(8,L)C*C16	21.0	UC48C	1210	33.6	24.8	14.55	12.45
TCHD36S41S3	T*(8,L)C*C20	21.0	FC/MC/PC35C	1170	33.8	23.8	14.50	12.55
TCHD36S41S3	T*(8,L)C*C20	21.0	FC/MC/PC43C	1190	34.6	25.4	14.80	12.50
TCHD36S41S3	T*(8,L)C*C20	21.0	FC/MC/PC48C	1155	35.2	26.0	15.35	13.10
TCHD36S41S3	T*(8,L)C*C20	21.0	HD36	1240	33.6	23.6	14.30	12.40
TCHD36S41S3	T*(8,L)C*C20	21.0	HD48	1155	34.8	25.4	15.20	13.05
TCHD36S41S3	T*(8,L)C*C20	21.0	UC48C	1155	33.6	24.8	14.75	12.60
TCHD36S41S3	T*(8,L)V*A12	14.5	FC/MC/PC37A	980	33.0	23.0	13.95	12.00
TCHD36S41S3	T*(8,L)V*B12	17.5	FC/MC/PC43B	1210	34.2	25.2	13.95	12.00
TCHD36S41S3	T*(8,L)V*B12	17.5	HD48	1210	34.6	25.2	14.50	12.45
TCHD36S41S3	T*(8,L)V*C16	21.0	FC/MC/PC43C	1205	34.4	25.4	14.60	12.50
TCHD36S41S3	T*(8,L)V*C16	21.0	FC/MC/PC48C	1210	35.0	26.0	15.10	13.00
TCHD36S41S3	T*(8,L)V*C16	21.0	HD48	1210	34.8	25.4	15.00	13.00
TCHD36S41S3	T*(8,L)V*C16	21.0	UC48C	1210	33.6	24.8	14.55	12.45
TCHD36S41S3	T*(8,L)V*C20	21.0	FC/MC/PC43C	1190	34.6	25.4	14.80	12.50
TCHD36S41S3	T*(8,L)V*C20	21.0	FC/MC/PC48C	1155	35.2	26.0	15.35	13.10
TCHD36S41S3	T*(8,L)V*C20	21.0	HD48	1155	34.8	25.4	15.20	13.05
TCHD36S41S3	T*(8,L)V*C20	21.0	UC48C	1155	33.6	24.8	14.75	12.60
TCHD36S41S3	T*9(C,V)*B12	17.5	FC/MC/PC35B	1190	33.4	24.6	13.65	11.85
TCHD36S41S3	T*9(C,V)*B12	17.5	FC/MC/PC43B	1200	34.2	25.2	14.00	12.10
TCHD36S41S3	T*9(C,V)*B12	17.5	HD36	1165	33.4	24.6	13.85	12.05
TCHD36S41S3	T*9(C,V)*B12	17.5	HD48	1150	34.4	25.2	14.25	12.35
TCHD36S41S3	T*9(C,V)*C16	21.0	FC/MC/PC35C	1215	33.6	24.8	14.05	12.15
TCHD36S41S3	T*9(C,V)*C16	21.0	FC/MC/PC43C	1240	34.2	25.2	14.20	12.25
TCHD36S41S3	T*9(C,V)*C16	21.0	FC/MC/PC48C	1195	35.0	25.8	14.85	12.80
TCHD36S41S3	T*9(C,V)*C16	21.0	HD36	1185	33.4	24.6	14.20	12.35
TCHD36S41S3	T*9(C,V)*C16	21.0	HD48	1195	34.6	25.2	14.70	12.70
TCHD36S41S3	T*9(C,V)*C16	21.0	UC48C	1195	33.4	24.6	14.25	12.25
TCHD36S41S3	T*9(C,V)*C20	21.0	FC/MC/PC35C	1275	34.2	25.7	13.80	12.00
TCHD36S41S3	T*9(C,V)*C20	21.0	FC/MC/PC43C	1200	34.4	25.4	14.65	12.60
TCHD36S41S3	T*9(C,V)*C20	21.0	FC/MC/PC48C	1315	35.2	26.8	14.55	12.55
TCHD36S41S3	T*9(C,V)*C20	21.0	HD36	1265	33.8	25.0	13.85	12.05
TCHD36S41S3	T*9(C,V)*C20	21.0	HD48	1300	34.8	26.2	14.35	12.40
TCHD36S41S3	T*9(C,V)*C20	21.0	UC48C	1265	33.8	25.4	14.00	12.00
TCHD36S41S3	T*9(C,V)*D20	24.5	FC/MC/PC48D	1240	35.2	26.2	15.00	13.00
TCHD36S41S3	T*9(C,V)*D20	24.5	HD48	1225	34.8	25.6	15.00	12.85
TCHD36S41S3	T*9(C,V)*D20	24.5	UC48D	1240	33.4	24.6	14.35	12.30
TCHD36S41S3	TM8X060A12MP11	14.5	FC/MC/PC37A	1125	33.6	24.3	13.95	11.90
TCHD36S41S3	TM8X080B12MP11	17.5	FC/MC/PC35B	1150	33.2	23.9	13.75	11.50

For Notes see Page 22

COOLING CAPACITY - With High Efficiency Motor Furnaces (Continued)

UNIT MODEL	FURNACE		COIL MODEL 1	COOLING				
	MODEL	WIDTH		RATED CFM	NET MBH		SEER	EER
					TOTAL	SENS.		
13 SEER AC WITH HIGH EFFICIENCY MOTOR FURNACES 2								
TCHD36S41S3	TM8X080B12MP11	17.5	FC/MC/PC43B	1175	33.6	24.3	14.00	11.95
TCHD36S41S3	TM8X080C16MP11	21.0	FC/MC/PC35C	1125	33.6	24.1	14.25	12.00
TCHD36S41S3	TM8X080C16MP11	21.0	FC/MC/PC43C	1150	33.8	24.5	14.75	12.50
TCHD36S41S3	TM8X080C16MP11	21.0	FC/MC/PC48C	1150	34.0	24.9	14.85	12.60
TCHD36S41S3	TM8X080C16MP11	21.0	FC/MC/PC48D	1175	34.0	24.9	14.50	12.25
TCHD36S41S3	TM8X080C16MP11	21.0	UC48C	1150	33.8	24.9	14.25	12.00
TCHD36S41S3	TM8X080C16MP11	21.0	UC48D	1175	33.8	24.9	14.25	12.25
TCHD36S41S3	TM8X100C16MP11	21.0	FC/MC/PC35C	1125	33.6	24.1	14.25	12.00
TCHD36S41S3	TM8X100C16MP11	21.0	FC/MC/PC43C	1150	33.8	24.5	14.75	12.50
TCHD36S41S3	TM8X100C16MP11	21.0	FC/MC/PC48C	1150	34.0	24.9	14.85	12.60
TCHD36S41S3	TM8X100C16MP11	21.0	FC/MC/PC48D	1175	34.0	24.9	14.50	12.25
TCHD36S41S3	TM8X100C16MP11	21.0	UC48C	1150	33.8	24.9	14.25	12.00
TCHD36S41S3	TM8X100C16MP11	21.0	UC48D	1175	33.8	24.9	14.25	12.25
TCHD36S41S3	TM8X100C20MP11	21.0	FC/MC/PC35C	1200	33.6	24.9	14.00	12.00
TCHD36S41S3	TM8X100C20MP11	21.0	FC/MC/PC43C	1200	34.4	25.3	14.65	12.50
TCHD36S41S3	TM8X100C20MP11	21.0	FC/MC/PC48C	1200	34.6	25.7	14.85	12.65
TCHD36S41S3	TM8X100C20MP11	21.0	FC/MC/PC48D	1200	34.6	25.7	14.50	12.25
TCHD36S41S3	TM8X100C20MP11	21.0	UC48C	1200	33.6	24.9	14.00	12.00
TCHD36S41S3	TM8X100C20MP11	21.0	UC48D	1200	33.6	24.9	14.00	12.00
TCHD36S41S3	TM8X120C20MP11	21.0	FC/MC/PC35C	1200	33.6	24.9	14.00	12.00
TCHD36S41S3	TM8X120C20MP11	21.0	FC/MC/PC43C	1200	34.4	25.3	14.65	12.50
TCHD36S41S3	TM8X120C20MP11	21.0	FC/MC/PC48C	1200	34.6	25.7	14.85	12.65
TCHD36S41S3	TM8X120C20MP11	21.0	FC/MC/PC48D	1200	34.6	25.7	14.50	12.25
TCHD36S41S3	TM8X120C20MP11	21.0	UC48C	1200	33.6	24.9	14.00	12.00
TCHD36S41S3	TM8X120C20MP11	21.0	UC48D	1200	33.6	24.9	14.00	12.00
TCHD36S41S3	TM9E060B12MP11	17.5	FC/MC/PC35B	1125	33.2	23.9	13.75	11.50
TCHD36S41S3	TM9E060B12MP11	17.5	FC/MC/PC43B	1125	33.6	24.3	14.00	11.95
TCHD36S41S3	TM9E080B12MP11	17.5	FC/MC/PC35B	1125	33.2	23.9	13.75	11.50
TCHD36S41S3	TM9E080B12MP11	17.5	FC/MC/PC43B	1125	33.6	24.3	14.00	11.95
TCHD36S41S3	TM9E080C16MP11	21.0	FC/MC/PC35C	1150	33.4	24.1	14.00	11.75
TCHD36S41S3	TM9E080C16MP11	21.0	FC/MC/PC43C	1175	33.8	24.5	14.25	12.25
TCHD36S41S3	TM9E080C16MP11	21.0	FC/MC/PC48C	1150	34.0	24.7	14.50	12.35
TCHD36S41S3	TM9E080C16MP11	21.0	FC/MC/PC48D	1175	34.0	24.7	14.25	12.00
TCHD36S41S3	TM9E080C16MP11	21.0	UC48C	1150	33.6	24.9	13.75	12.00
TCHD36S41S3	TM9E080C16MP11	21.0	UC48D	1175	33.6	24.9	13.75	12.00
TCHD36S41S3	TM9E100C16MP11	21.0	FC/MC/PC35C	1150	33.4	24.1	14.00	11.75
TCHD36S41S3	TM9E100C16MP11	21.0	FC/MC/PC43C	1175	33.8	24.5	14.25	12.25
TCHD36S41S3	TM9E100C16MP11	21.0	FC/MC/PC48C	1150	34.0	24.7	14.50	12.35
TCHD36S41S3	TM9E100C16MP11	21.0	FC/MC/PC48D	1175	34.0	24.7	14.25	12.00
TCHD36S41S3	TM9E100C16MP11	21.0	UC48C	1150	33.6	24.9	13.75	12.00
TCHD36S41S3	TM9E100C16MP11	21.0	UC48D	1175	33.6	24.9	13.75	12.00
TCHD36S41S3	TM9E100C20MP11	21.0	FC/MC/PC35C	1150	33.4	24.1	14.00	12.00
TCHD36S41S3	TM9E100C20MP11	21.0	FC/MC/PC43C	1150	33.8	24.5	14.55	12.25
TCHD36S41S3	TM9E100C20MP11	21.0	FC/MC/PC48C	1150	34.0	24.7	14.55	12.40
TCHD36S41S3	TM9E100C20MP11	21.0	FC/MC/PC48D	1175	34.0	24.9	14.50	12.25
TCHD36S41S3	TM9E100C20MP11	21.0	UC48C	1150	33.6	24.9	14.00	12.00
TCHD36S41S3	TM9E100C20MP11	21.0	UC48D	1175	33.6	24.9	14.00	12.00
TCHD36S41S3	TM9E120D20MP11	24.5	FC/MC/PC48D	1175	34.0	24.9	14.75	12.50
TCHD36S41S3	TM9E120D20MP11	24.5	UC48D	1175	33.8	24.9	14.00	12.00
TCHD36S41S3	TM9X060B12MP11	17.5	FC/MC/PC35B	1125	33.2	23.9	13.75	11.50
TCHD36S41S3	TM9X060B12MP11	17.5	FC/MC/PC43B	1125	33.6	24.3	14.00	11.95
TCHD36S41S3	TM9X080B12MP11	17.5	FC/MC/PC35B	1125	33.2	23.9	13.75	11.50
TCHD36S41S3	TM9X080B12MP11	17.5	FC/MC/PC43B	1125	33.6	24.3	14.00	11.95
TCHD36S41S3	TM9X080C16MP11	21.0	FC/MC/PC35C	1150	33.4	24.1	14.00	11.75
TCHD36S41S3	TM9X080C16MP11	21.0	FC/MC/PC43C	1175	33.8	24.5	14.25	12.25
TCHD36S41S3	TM9X080C16MP11	21.0	FC/MC/PC48C	1150	34.0	24.7	14.50	12.35

For Notes see Page 22

COOLING CAPACITY - With High Efficiency Motor Furnaces (Continued)

UNIT MODEL	FURNACE		COIL MODEL ¹	COOLING				
	MODEL	WIDTH		RATED CFM	NET MBH		SEER	EER
					TOTAL	SENS.		
13 SEER AC WITH HIGH EFFICIENCY MOTOR FURNACES ²								
TCHD36S41S3	TM9X080C16MP11	21.0	FC/MC/PC48D	1175	34.0	24.7	14.25	12.00
TCHD36S41S3	TM9X080C16MP11	21.0	UC48C	1150	33.6	24.9	13.75	12.00
TCHD36S41S3	TM9X080C16MP11	21.0	UC48D	1175	33.6	24.9	13.75	12.00
TCHD36S41S3	TM9X100C16MP11	21.0	FC/MC/PC35C	1150	33.4	24.1	14.00	11.75
TCHD36S41S3	TM9X100C16MP11	21.0	FC/MC/PC43C	1175	33.8	24.5	14.25	12.25
TCHD36S41S3	TM9X100C16MP11	21.0	FC/MC/PC48C	1150	34.0	24.7	14.50	12.35
TCHD36S41S3	TM9X100C16MP11	21.0	FC/MC/PC48D	1175	34.0	24.7	14.25	12.00
TCHD36S41S3	TM9X100C16MP11	21.0	UC48C	1150	33.6	24.9	13.75	12.00
TCHD36S41S3	TM9X100C16MP11	21.0	UC48D	1175	33.6	24.9	13.75	12.00
TCHD36S41S3	TM9X100C20MP11	21.0	FC/MC/PC35C	1150	33.4	24.1	14.00	12.00
TCHD36S41S3	TM9X100C20MP11	21.0	FC/MC/PC43C	1150	33.8	24.5	14.55	12.25
TCHD36S41S3	TM9X100C20MP11	21.0	FC/MC/PC48C	1150	34.0	24.7	14.55	12.40
TCHD36S41S3	TM9X100C20MP11	21.0	FC/MC/PC48D	1175	34.0	24.9	14.50	12.25
TCHD36S41S3	TM9X100C20MP11	21.0	UC48C	1150	33.6	24.9	14.00	12.00
TCHD36S41S3	TM9X100C20MP11	21.0	UC48D	1175	33.6	24.9	14.00	12.00
TCHD36S41S3	TM9X120D20MP11	24.5	FC/MC/PC48D	1175	34.0	24.9	14.75	12.50
TCHD36S41S3	TM9X120D20MP11	24.5	UC48D	1175	33.8	24.9	14.00	12.00
TCHD36S41S3	TMLX060A12MP11	14.5	FC/MC/PC37A	1125	33.6	24.3	13.95	11.90
TCHD36S41S3	TMLX080B12MP11	17.5	FC/MC/PC35B	1150	33.2	23.9	13.75	11.50
TCHD36S41S3	TMLX080B12MP11	17.5	FC/MC/PC43B	1175	33.6	24.3	14.00	11.95
TCHD36S41S3	TMLX080C16MP11	21.0	FC/MC/PC35C	1125	33.6	24.1	14.25	12.00
TCHD36S41S3	TMLX080C16MP11	21.0	FC/MC/PC43C	1150	33.8	24.5	14.75	12.50
TCHD36S41S3	TMLX080C16MP11	21.0	FC/MC/PC48C	1150	34.0	24.9	14.85	12.60
TCHD36S41S3	TMLX080C16MP11	21.0	FC/MC/PC48D	1175	34.0	24.9	14.50	12.25
TCHD36S41S3	TMLX080C16MP11	21.0	UC48C	1150	33.8	24.9	14.25	12.00
TCHD36S41S3	TMLX080C16MP11	21.0	UC48D	1175	33.8	24.9	14.25	12.25
TCHD36S41S3	TMLX100C16MP11	21.0	FC/MC/PC35C	1125	33.6	24.1	14.25	12.00
TCHD36S41S3	TMLX100C16MP11	21.0	FC/MC/PC43C	1150	33.8	24.5	14.75	12.50
TCHD36S41S3	TMLX100C16MP11	21.0	FC/MC/PC48C	1150	34.0	24.9	14.85	12.60
TCHD36S41S3	TMLX100C16MP11	21.0	FC/MC/PC48D	1175	34.0	24.9	14.50	12.25
TCHD36S41S3	TMLX100C16MP11	21.0	UC48C	1150	33.8	24.9	14.25	12.00
TCHD36S41S3	TMLX100C16MP11	21.0	UC48D	1175	33.8	24.9	14.25	12.25
TCHD36S41S3	TMLX100C20MP11	21.0	FC/MC/PC35C	1200	33.6	24.9	14.00	12.00
TCHD36S41S3	TMLX100C20MP11	21.0	FC/MC/PC43C	1200	34.4	25.3	14.65	12.50
TCHD36S41S3	TMLX100C20MP11	21.0	FC/MC/PC48C	1200	34.6	25.7	14.85	12.65
TCHD36S41S3	TMLX100C20MP11	21.0	FC/MC/PC48D	1200	34.6	25.7	14.50	12.25
TCHD36S41S3	TMLX100C20MP11	21.0	UC48C	1200	33.6	24.9	14.00	12.00
TCHD36S41S3	TMLX100C20MP11	21.0	UC48D	1200	33.6	24.9	14.00	12.00
TCHD36S41S3	TMLX120C20MP11	21.0	FC/MC/PC35C	1200	33.6	24.9	14.00	12.00
TCHD36S41S3	TMLX120C20MP11	21.0	FC/MC/PC43C	1200	34.4	25.3	14.65	12.50
TCHD36S41S3	TMLX120C20MP11	21.0	FC/MC/PC48C	1200	34.6	25.7	14.85	12.65
TCHD36S41S3	TMLX120C20MP11	21.0	FC/MC/PC48D	1200	34.6	25.7	14.50	12.25
TCHD36S41S3	TMLX120C20MP11	21.0	UC48C	1200	33.6	24.9	14.00	12.00
TCHD36S41S3	TMLX120C20MP11	21.0	UC48D	1200	33.6	24.9	14.00	12.00
TCHD36S41S3	Y*(8,L)C*A12	14.5	FC/MC/PC37A	980	33.0	23.0	13.95	12.00
TCHD36S41S3	Y*(8,L)C*B12	17.5	FC/MC/PC43B	1210	34.2	25.2	13.95	12.00
TCHD36S41S3	Y*(8,L)C*B12	17.5	HD48	1210	34.6	25.2	14.50	12.45
TCHD36S41S3	Y*(8,L)C*C16	21.0	FC/MC/PC43C	1205	34.4	25.4	14.60	12.50
TCHD36S41S3	Y*(8,L)C*C16	21.0	FC/MC/PC48C	1210	35.0	26.0	15.10	13.00
TCHD36S41S3	Y*(8,L)C*C16	21.0	HD48	1210	34.8	25.4	15.00	13.00
TCHD36S41S3	Y*(8,L)C*C16	21.0	UC48C	1210	33.6	24.8	14.55	12.45
TCHD36S41S3	Y*(8,L)C*C20	21.0	FC/MC/PC43C	1190	34.6	25.4	14.80	12.50
TCHD36S41S3	Y*(8,L)C*C20	21.0	FC/MC/PC48C	1155	35.2	26.0	15.35	13.10
TCHD36S41S3	Y*(8,L)C*C20	21.0	HD48	1155	34.8	25.4	15.20	13.05
TCHD36S41S3	Y*(8,L)C*C20	21.0	UC48C	1155	33.6	24.8	14.75	12.60
TCHD36S41S3	Y*9C*B12	17.5	FC/MC/PC43B	1200	34.2	25.2	14.00	12.10

For Notes see Page 22

COOLING CAPACITY - With High Efficiency Motor Furnaces (Continued)

UNIT MODEL	FURNACE		COIL MODEL 1	COOLING				
	MODEL	WIDTH		RATED CFM	NET MBH		SEER	EER
					TOTAL	SENS.		
13 SEER AC WITH HIGH EFFICIENCY MOTOR FURNACES 2								
TCHD36S41S3	Y*9C*B12	17.5	HD48	1150	34.4	25.2	14.25	12.35
TCHD36S41S3	Y*9C*C16	21.0	FC/MC/PC43C	1240	34.2	25.2	14.20	12.25
TCHD36S41S3	Y*9C*C16	21.0	FC/MC/PC48C	1195	35.0	25.8	14.85	12.80
TCHD36S41S3	Y*9C*C16	21.0	HD48	1195	34.6	25.2	14.70	12.70
TCHD36S41S3	Y*9C*C16	21.0	UC48C	1195	33.4	24.6	14.25	12.25
TCHD36S41S3	Y*9C*C20	21.0	FC/MC/PC43C	1200	34.4	25.4	14.65	12.60
TCHD36S41S3	Y*9C*C20	21.0	FC/MC/PC48C	1315	35.2	26.8	14.55	12.55
TCHD36S41S3	Y*9C*C20	21.0	HD48	1300	34.8	26.2	14.35	12.40
TCHD36S41S3	Y*9C*C20	21.0	UC48C	1265	33.8	25.4	14.00	12.00
TCHD36S41S3	Y*9C*D20	24.5	FC/MC/PC48D	1240	35.2	26.2	15.00	13.00
TCHD36S41S3	Y*9C*D20	24.5	HD48	1225	34.8	25.6	15.00	12.85
TCHD36S41S3	Y*9C*D20	24.5	UC48D	1240	33.4	24.6	14.35	12.30
TCHD48S41S3	T*(8,L)C*C16	21.0	FC/MC/PC48C	1615	47.0	34.2	13.25	11.50
TCHD48S41S3	T*(8,L)C*C16	21.0	FC/PC60C	1625	46.5	33.7	13.25	11.50
TCHD48S41S3	T*(8,L)C*C16	21.0	FC64D	1635	49.0	35.8	14.00	12.25
TCHD48S41S3	T*(8,L)C*C16	21.0	HD48	1615	47.0	34.2	13.45	11.65
TCHD48S41S3	T*(8,L)C*C16	21.0	HD60	1625	47.5	34.4	13.70	11.85
TCHD48S41S3	T*(8,L)C*C16	21.0	UC48C	1615	45.5	33.2	13.10	11.35
TCHD48S41S3	T*(8,L)C*C16	21.0	UC60C	1625	46.0	32.8	13.30	11.50
TCHD48S41S3	T*(8,L)C*C20	21.0	FC/MC/PC48C	1640	47.0	34.0	13.45	11.65
TCHD48S41S3	T*(8,L)C*C20	21.0	FC/PC60C	1605	47.0	34.2	14.00	11.60
TCHD48S41S3	T*(8,L)C*C20	21.0	FC64D	1630	49.0	35.8	14.25	12.25
TCHD48S41S3	T*(8,L)C*C20	21.0	HD48	1640	47.0	34.2	13.45	11.65
TCHD48S41S3	T*(8,L)C*C20	21.0	HD60	1605	47.5	34.6	14.00	12.05
TCHD48S41S3	T*(8,L)C*C20	21.0	UC48C	1640	45.5	33.0	13.05	11.35
TCHD48S41S3	T*(8,L)C*C20	21.0	UC60C	1605	46.0	33.0	13.55	11.70
TCHD48S41S3	T*(8,L)V*C16	21.0	FC/MC/PC48C	1615	47.0	34.2	13.25	11.50
TCHD48S41S3	T*(8,L)V*C16	21.0	FC/PC60C	1625	46.5	33.7	13.25	11.50
TCHD48S41S3	T*(8,L)V*C16	21.0	FC64D	1635	49.0	35.8	14.00	12.25
TCHD48S41S3	T*(8,L)V*C16	21.0	HD60	1625	47.5	34.4	13.70	11.85
TCHD48S41S3	T*(8,L)V*C16	21.0	UC48C	1615	45.5	33.2	13.10	11.35
TCHD48S41S3	T*(8,L)V*C16	21.0	UC60C	1625	46.0	32.8	13.30	11.50
TCHD48S41S3	T*(8,L)V*C20	21.0	FC/MC/PC48C	1640	47.0	34.0	13.45	11.65
TCHD48S41S3	T*(8,L)V*C20	21.0	FC/PC60C	1605	47.0	34.2	14.00	11.60
TCHD48S41S3	T*(8,L)V*C20	21.0	FC64D	1630	49.0	35.8	14.25	12.25
TCHD48S41S3	T*(8,L)V*C20	21.0	HD60	1605	47.5	34.6	14.00	12.05
TCHD48S41S3	T*(8,L)V*C20	21.0	UC48C	1640	45.5	33.0	13.05	11.35
TCHD48S41S3	T*(8,L)V*C20	21.0	UC60C	1605	46.0	33.0	13.55	11.70
TCHD48S41S3	T*9(C,V)*C16	21.0	FC/MC/PC48C	1590	47.0	33.8	13.45	11.65
TCHD48S41S3	T*9(C,V)*C16	21.0	FC/PC60C	1590	47.0	34.4	13.40	11.65
TCHD48S41S3	T*9(C,V)*C16	21.0	FC64D	1590	49.0	35.6	14.00	12.00
TCHD48S41S3	T*9(C,V)*C16	21.0	HD48	1590	47.0	34.2	13.35	11.60
TCHD48S41S3	T*9(C,V)*C16	21.0	HD60	1590	47.0	34.2	13.50	11.65
TCHD48S41S3	T*9(C,V)*C16	21.0	UC48C	1590	45.5	33.0	13.00	11.30
TCHD48S41S3	T*9(C,V)*C16	21.0	UC60C	1590	45.5	32.8	13.05	11.30
TCHD48S41S3	T*9(C,V)*C20	21.0	FC/MC/PC48C	1655	47.5	34.4	13.50	11.70
TCHD48S41S3	T*9(C,V)*C20	21.0	FC/PC60C	1655	47.0	34.4	13.35	11.65
TCHD48S41S3	T*9(C,V)*C20	21.0	FC64D	1655	49.0	35.6	13.75	11.75
TCHD48S41S3	T*9(C,V)*C20	21.0	HD48	1655	47.0	34.2	13.35	11.60
TCHD48S41S3	T*9(C,V)*C20	21.0	HD60	1655	47.0	34.2	13.50	11.65
TCHD48S41S3	T*9(C,V)*C20	21.0	UC48C	1655	45.5	33.0	13.00	11.30
TCHD48S41S3	T*9(C,V)*C20	21.0	UC60C	1655	45.5	32.8	13.05	11.30
TCHD48S41S3	T*9(C,V)*D20	24.5	FC/MC/PC48D	1645	47.5	34.4	13.50	11.70
TCHD48S41S3	T*9(C,V)*D20	24.5	FC/MC/PC60D	1615	47.0	34.4	13.50	11.75
TCHD48S41S3	T*9(C,V)*D20	24.5	FC/MC62D	1630	47.5	34.6	13.65	11.85
TCHD48S41S3	T*9(C,V)*D20	24.5	FC64D	1630	49.0	35.6	13.75	12.00

For Notes see Page 22

COOLING CAPACITY - With High Efficiency Motor Furnaces (Continued)

UNIT MODEL	FURNACE		COIL MODEL ¹	COOLING				
	MODEL	WIDTH		RATED CFM	NET MBH		SEER	EER
					TOTAL	SENS.		
13 SEER AC WITH HIGH EFFICIENCY MOTOR FURNACES ²								
TCHD48S41S3	T*9(C,V)*D20	24.5	HD48	1645	47.0	34.2	13.35	11.60
TCHD48S41S3	T*9(C,V)*D20	24.5	HD60	1615	47.5	34.4	13.60	11.75
TCHD48S41S3	T*9(C,V)*D20	24.5	UC48D	1645	45.5	33.0	13.00	11.30
TCHD48S41S3	T*9(C,V)*D20	24.5	UC60D	1615	46.0	32.8	13.20	11.40
TCHD48S41S3	TM8X080C16MP11	21.0	FC/MC/PC48C	1525	46.0	32.5	13.35	11.50
TCHD48S41S3	TM8X080C16MP11	21.0	FC/MC/PC60D	1550	46.5	33.1	13.35	11.25
TCHD48S41S3	TM8X080C16MP11	21.0	FC/MC62D	1550	46.5	33.3	13.40	11.50
TCHD48S41S3	TM8X080C16MP11	21.0	FC/PC60C	1525	46.5	33.1	13.35	11.50
TCHD48S41S3	TM8X080C16MP11	21.0	FC64D	1550	48.0	34.3	13.85	12.05
TCHD48S41S3	TM8X100C16MP11	21.0	FC/MC/PC48C	1525	46.0	32.5	13.35	11.50
TCHD48S41S3	TM8X100C16MP11	21.0	FC/MC/PC60D	1550	46.5	33.1	13.35	11.25
TCHD48S41S3	TM8X100C16MP11	21.0	FC/MC62D	1550	46.5	33.3	13.40	11.50
TCHD48S41S3	TM8X100C16MP11	21.0	FC/PC60C	1525	46.5	33.1	13.35	11.50
TCHD48S41S3	TM8X100C16MP11	21.0	FC64D	1550	48.0	34.3	13.85	12.05
TCHD48S41S3	TM8X100C20MP11	21.0	FC/MC/PC48C	1550	46.0	32.9	13.50	11.75
TCHD48S41S3	TM8X100C20MP11	21.0	FC/MC/PC48D	1575	46.0	32.9	13.50	11.50
TCHD48S41S3	TM8X100C20MP11	21.0	FC/MC/PC60D	1575	46.5	33.1	13.50	11.50
TCHD48S41S3	TM8X100C20MP11	21.0	FC/MC62D	1575	46.5	33.3	13.60	11.75
TCHD48S41S3	TM8X100C20MP11	21.0	FC/PC60C	1550	46.5	33.1	13.50	11.50
TCHD48S41S3	TM8X100C20MP11	21.0	FC64D	1600	48.0	34.3	14.00	12.20
TCHD48S41S3	TM8X100C20MP11	21.0	UC60C	1550	46.0	32.1	13.45	11.65
TCHD48S41S3	TM8X100C20MP11	21.0	UC60D	1575	46.0	32.1	13.50	11.70
TCHD48S41S3	TM8X120C20MP11	21.0	FC/MC/PC48C	1550	46.0	32.9	13.50	11.75
TCHD48S41S3	TM8X120C20MP11	21.0	FC/MC/PC48D	1575	46.0	32.9	13.50	11.50
TCHD48S41S3	TM8X120C20MP11	21.0	FC/MC/PC60D	1575	46.5	33.1	13.50	11.50
TCHD48S41S3	TM8X120C20MP11	21.0	FC/MC62D	1575	46.5	33.3	13.60	11.75
TCHD48S41S3	TM8X120C20MP11	21.0	FC/PC60C	1550	46.5	33.1	13.50	11.50
TCHD48S41S3	TM8X120C20MP11	21.0	FC64D	1600	48.0	34.3	14.00	12.20
TCHD48S41S3	TM8X120C20MP11	21.0	UC60C	1550	46.0	32.1	13.45	11.65
TCHD48S41S3	TM8X120C20MP11	21.0	UC60D	1575	46.0	32.1	13.50	11.70
TCHD48S41S3	TM9E100C20MP11	21.0	FC/MC62D	1550	46.5	33.3	13.45	11.50
TCHD48S41S3	TM9E100C20MP11	21.0	FC64D	1550	48.0	34.3	13.85	12.05
TCHD48S41S3	TM9E120D20MP11	24.5	FC/MC/PC48D	1525	46.0	32.5	13.45	11.50
TCHD48S41S3	TM9E120D20MP11	24.5	FC/MC/PC60D	1550	46.5	33.1	13.50	11.75
TCHD48S41S3	TM9E120D20MP11	24.5	FC/MC62D	1550	46.5	33.3	13.50	11.50
TCHD48S41S3	TM9E120D20MP11	24.5	FC64D	1525	48.0	34.3	13.95	12.10
TCHD48S41S3	TM9E120D20MP11	24.5	UC60D	1550	46.0	32.1	13.35	11.50
TCHD48S41S3	TM9X100C20MP11	21.0	FC/MC62D	1550	46.5	33.3	13.45	11.50
TCHD48S41S3	TM9X100C20MP11	21.0	FC64D	1550	48.0	34.3	13.85	12.05
TCHD48S41S3	TM9X120D20MP11	24.5	FC/MC/PC48D	1525	46.0	32.5	13.45	11.50
TCHD48S41S3	TM9X120D20MP11	24.5	FC/MC/PC60D	1550	46.5	33.1	13.50	11.75
TCHD48S41S3	TM9X120D20MP11	24.5	FC/MC62D	1550	46.5	33.3	13.50	11.50
TCHD48S41S3	TM9X120D20MP11	24.5	FC64D	1525	48.0	34.3	13.95	12.10
TCHD48S41S3	TM9X120D20MP11	24.5	UC60D	1550	46.0	32.1	13.35	11.50
TCHD48S41S3	TMLX080C16MP11	21.0	FC/MC/PC48C	1525	46.0	32.5	13.35	11.50
TCHD48S41S3	TMLX080C16MP11	21.0	FC/MC/PC60D	1550	46.5	33.1	13.35	11.25
TCHD48S41S3	TMLX080C16MP11	21.0	FC/MC62D	1550	46.5	33.3	13.40	11.50
TCHD48S41S3	TMLX080C16MP11	21.0	FC/PC60C	1525	46.5	33.1	13.35	11.50
TCHD48S41S3	TMLX080C16MP11	21.0	FC64D	1550	48.0	34.3	13.85	12.05
TCHD48S41S3	TMLX100C16MP11	21.0	FC/MC/PC48C	1525	46.0	32.5	13.35	11.50
TCHD48S41S3	TMLX100C16MP11	21.0	FC/MC/PC60D	1550	46.5	33.1	13.35	11.25
TCHD48S41S3	TMLX100C16MP11	21.0	FC/MC62D	1550	46.5	33.3	13.40	11.50
TCHD48S41S3	TMLX100C16MP11	21.0	FC/PC60C	1525	46.5	33.1	13.35	11.50
TCHD48S41S3	TMLX100C16MP11	21.0	FC64D	1550	48.0	34.3	13.85	12.05
TCHD48S41S3	TMLX100C20MP11	21.0	FC/MC/PC48C	1550	46.0	32.9	13.50	11.75
TCHD48S41S3	TMLX100C20MP11	21.0	FC/MC/PC48D	1575	46.0	32.9	13.50	11.50

For Notes see Page 22

COOLING CAPACITY - With High Efficiency Motor Furnaces (Continued)

UNIT MODEL	FURNACE		COIL MODEL ¹	COOLING				
	MODEL	WIDTH		RATED CFM	NET MBH		SEER	EER
					TOTAL	SENS.		
13 SEER AC WITH HIGH EFFICIENCY MOTOR FURNACES ²								
TCHD48S41S3	TMLX100C20MP11	21.0	FC/MC/PC60D	1575	46.5	33.1	13.50	11.50
TCHD48S41S3	TMLX100C20MP11	21.0	FC/MC62D	1575	46.5	33.3	13.60	11.75
TCHD48S41S3	TMLX100C20MP11	21.0	FC/PC60C	1550	46.5	33.1	13.50	11.50
TCHD48S41S3	TMLX100C20MP11	21.0	FC64D	1600	48.0	34.3	14.00	12.20
TCHD48S41S3	TMLX100C20MP11	21.0	UC60C	1550	46.0	32.1	13.45	11.65
TCHD48S41S3	TMLX100C20MP11	21.0	UC60D	1575	46.0	32.1	13.50	11.70
TCHD48S41S3	TMLX120C20MP11	21.0	FC/MC/PC48C	1550	46.0	32.9	13.50	11.75
TCHD48S41S3	TMLX120C20MP11	21.0	FC/MC/PC48D	1575	46.0	32.9	13.50	11.50
TCHD48S41S3	TMLX120C20MP11	21.0	FC/MC/PC60D	1575	46.5	33.1	13.50	11.50
TCHD48S41S3	TMLX120C20MP11	21.0	FC/MC62D	1575	46.5	33.3	13.60	11.75
TCHD48S41S3	TMLX120C20MP11	21.0	FC/PC60C	1550	46.5	33.1	13.50	11.50
TCHD48S41S3	TMLX120C20MP11	21.0	FC64D	1600	48.0	34.3	14.00	12.20
TCHD48S41S3	TMLX120C20MP11	21.0	UC60C	1550	46.0	32.1	13.45	11.65
TCHD48S41S3	TMLX120C20MP11	21.0	UC60D	1575	46.0	32.1	13.50	11.70
TCHD48S41S3	Y*(8,L)C*C16	21.0	FC/MC/PC48C	1615	47.0	34.2	13.25	11.50
TCHD48S41S3	Y*(8,L)C*C16	21.0	FC/PC60C	1625	46.5	33.7	13.25	11.50
TCHD48S41S3	Y*(8,L)C*C16	21.0	FC64D	1635	49.0	35.8	14.00	12.25
TCHD48S41S3	Y*(8,L)C*C16	21.0	HD60	1625	47.5	34.4	13.70	11.85
TCHD48S41S3	Y*(8,L)C*C16	21.0	UC48C	1615	45.5	33.2	13.10	11.35
TCHD48S41S3	Y*(8,L)C*C16	21.0	UC60C	1625	46.0	32.8	13.30	11.50
TCHD48S41S3	Y*(8,L)C*C20	21.0	FC/MC/PC48C	1640	47.0	34.0	13.45	11.65
TCHD48S41S3	Y*(8,L)C*C20	21.0	FC/PC60C	1605	47.0	34.2	14.00	11.60
TCHD48S41S3	Y*(8,L)C*C20	21.0	FC64D	1630	49.0	35.8	14.25	12.25
TCHD48S41S3	Y*(8,L)C*C20	21.0	HD60	1605	47.5	34.6	14.00	12.05
TCHD48S41S3	Y*(8,L)C*C20	21.0	UC48C	1640	45.5	33.0	13.05	11.35
TCHD48S41S3	Y*(8,L)C*C20	21.0	UC60C	1605	46.0	33.0	13.55	11.70
TCHD48S41S3	Y*9C*C16	21.0	FC/MC/PC48C	1590	47.0	33.8	13.45	11.65
TCHD48S41S3	Y*9C*C16	21.0	FC/PC60C	1590	47.0	34.4	13.40	11.65
TCHD48S41S3	Y*9C*C16	21.0	FC64D	1590	49.0	35.6	14.00	12.00
TCHD48S41S3	Y*9C*C16	21.0	HD60	1590	47.0	34.2	13.50	11.65
TCHD48S41S3	Y*9C*C16	21.0	UC48C	1590	45.5	33.0	13.00	11.30
TCHD48S41S3	Y*9C*C16	21.0	UC60C	1590	45.5	32.8	13.05	11.30
TCHD48S41S3	Y*9C*C20	21.0	FC/MC/PC48C	1655	47.5	34.4	13.50	11.70
TCHD48S41S3	Y*9C*C20	21.0	FC/PC60C	1655	47.0	34.4	13.35	11.65
TCHD48S41S3	Y*9C*C20	21.0	FC64D	1655	49.0	35.6	13.75	11.75
TCHD48S41S3	Y*9C*C20	21.0	HD60	1655	47.0	34.2	13.50	11.65
TCHD48S41S3	Y*9C*C20	21.0	UC48C	1655	45.5	33.0	13.00	11.30
TCHD48S41S3	Y*9C*C20	21.0	UC60C	1655	45.5	32.8	13.05	11.30
TCHD48S41S3	Y*9C*D20	24.5	FC/MC/PC48D	1645	47.5	34.4	13.50	11.70
TCHD48S41S3	Y*9C*D20	24.5	FC/MC/PC60D	1615	47.0	34.4	13.50	11.75
TCHD48S41S3	Y*9C*D20	24.5	FC/MC62D	1630	47.5	34.6	13.65	11.85
TCHD48S41S3	Y*9C*D20	24.5	FC64D	1630	49.0	35.6	13.75	12.00
TCHD48S41S3	Y*9C*D20	24.5	HD60	1615	47.5	34.4	13.60	11.75
TCHD48S41S3	Y*9C*D20	24.5	UC48D	1645	45.5	33.0	13.00	11.30
TCHD48S41S3	Y*9C*D20	24.5	UC60D	1615	46.0	32.8	13.20	11.40
TCHD60S41S3	T*(8,L)C*C16	21.0	HD60	1740	57.0	40.0	13.05	11.15
TCHD60S41S3	T*(8,L)C*C20	21.0	FC/MC62D	1615	56.5	38.5	13.30	11.30
TCHD60S41S3	T*(8,L)C*C20	21.0	HD60	1605	56.0	38.0	13.40	11.40
TCHD60S41S3	T*(8,L)V*C16	21.0	HD60	1740	57.0	40.0	13.05	11.15
TCHD60S41S3	T*(8,L)V*C20	21.0	FC/MC62D	1615	56.5	38.5	13.30	11.30
TCHD60S41S3	T*9(C,V)*C16	21.0	HD60	1590	56.0	38.0	13.15	11.20
TCHD60S41S3	T*9(C,V)*C20	21.0	FC/MC62D	1655	56.5	38.0	13.15	11.10
TCHD60S41S3	T*9(C,V)*C20	21.0	FC64D	1655	58.0	40.0	13.25	11.25
TCHD60S41S3	T*9(C,V)*C20	21.0	HD60	1655	56.0	38.0	13.00	11.10
TCHD60S41S3	T*9(C,V)*D20	24.5	FC/MC62D	1630	56.5	38.0	13.30	11.20
TCHD60S41S3	T*9(C,V)*D20	24.5	FC64D	1630	58.0	40.0	13.50	11.50

For Notes see Page 22

COOLING CAPACITY - With High Efficiency Motor Furnaces (Continued)

UNIT MODEL	FURNACE		COIL MODEL ¹	COOLING				
	MODEL	WIDTH		RATED CFM	NET MBH		SEER	EER
					TOTAL	SENS.		
13 SEER AC WITH HIGH EFFICIENCY MOTOR FURNACES ²								
TCHD60S41S3	T*9(C,V)*D20	24.5	HD60	1615	56.0	38.0	13.10	11.15
TCHD60S41S3	TM8X100C20MP11	21.0	FC/MC62D	1575	55.5	37.5	13.25	11.20
TCHD60S41S3	TM8X100C20MP11	21.0	FC64D	1600	57.0	38.7	13.65	11.55
TCHD60S41S3	TM8X120C20MP11	21.0	FC/MC62D	1575	55.5	37.5	13.25	11.20
TCHD60S41S3	TM8X120C20MP11	21.0	FC64D	1600	57.0	38.7	13.65	11.55
TCHD60S41S3	TM9E100C20MP11	21.0	FC64D	1550	56.5	37.7	13.45	11.35
TCHD60S41S3	TM9E120D20MP11	24.5	FC64D	1525	56.5	37.7	13.55	11.40
TCHD60S41S3	TM9X100C20MP11	21.0	FC64D	1550	56.5	37.7	13.45	11.35
TCHD60S41S3	TM9X120D20MP11	24.5	FC64D	1525	56.5	37.7	13.55	11.40
TCHD60S41S3	TMLX100C20MP11	21.0	FC/MC62D	1575	55.5	37.5	13.25	11.20
TCHD60S41S3	TMLX100C20MP11	21.0	FC64D	1600	57.0	38.7	13.65	11.55
TCHD60S41S3	TMLX120C20MP11	21.0	FC/MC62D	1575	55.5	37.5	13.25	11.20
TCHD60S41S3	TMLX120C20MP11	21.0	FC64D	1600	57.0	38.7	13.65	11.55
TCHD60S41S3	Y*(8,L)C*C16	21.0	HD60	1740	57.0	40.0	13.05	11.15
TCHD60S41S3	Y*(8,L)C*C20	21.0	FC/MC62D	1615	56.5	38.5	13.30	11.30
TCHD60S41S3	Y*9C*C16	21.0	HD60	1590	56.0	38.0	13.15	11.20
TCHD60S41S3	Y*9C*C20	21.0	FC/MC62D	1655	56.5	38.0	13.15	11.10
TCHD60S41S3	Y*9C*C20	21.0	FC64D	1655	58.0	40.0	13.25	11.25
TCHD60S41S3	Y*9C*D20	24.5	FC/MC62D	1630	56.5	38.0	13.30	11.20
TCHD60S41S3	Y*9C*D20	24.5	FC64D	1630	58.0	40.0	13.50	11.50

1. MC coils available with a factory installed horizontal drain pan. See price pages for specific model number.

2. High Efficiency Motor Furnaces have B.O.D (Blower on Delay) standard.

PSC furnaces, such as the TG8S, TGLS, and TG9S, use Coil Only Ratings.

ACCESSORIES

Refer to Price Manual for specific model numbers.

Application Limits		
Maximum Lineset Equivalent Length		200 Ft
Outdoor Ambient Temperature Limits		
Cooling Operation	Maximum DB	115°F
	Minimum DB	50°F

Long Lineset Applications - For installations with more than 75' of equivalent lineset length, refer to the current version of the **Piping Application Guide 247077-UAD-H-0209**, available in the Application Bulletins section on UPGnet.

Off Cycle Timer Delay - Provides a 5-minute off cycle to prevent rapid recycling of the compressor.

Start Assist Kit (S1-2SA067) - Provides increased starting torque for areas with low voltage. See Hard Start Kit Accessory Installation Manual for Hard Start Kit part number for each model.

TXV Kits - S1-1TVM series thermal expansion valves precisely meter refrigerant for optimum performance over a wide range of conditions. See System Charge table for TXV part number for each model.

Low Ambient Pressure Switch Kit (S1-2LA06700424) - Allows the use of air conditioning at low outdoor ambient temperatures down to +20°F (-7°C). For use with single-stage models containing R-410A refrigerant only.

Thermostats - Compatible thermostat controls are available through accessory sourcing. For optimum performance and installation, refer to the UPGNET "Low Voltage Wiring Diagram" document to select and apply controls.

SOUND POWER LEVEL - TYPICAL OCTAVE BAND SPECTRUM (without tone adjustment)

Model Number	Octave Band Sound Power Level (db re. 1-pW)									dBA	SQI
	63	125	250	500	1000	2000	4000	8000			
TCHD18S41S3	71	71	76	65	62	57	52	48	70	19.0	
TCHD24S41S4	73	78	69	67	65	60	57	58	70	19.1	
TCHD30S41S3	73	78	69	67	65	60	57	58	70	19.1	
TCHD36S41S3	74	77	68	67	66	61	58	58	71	19.1	
TCHD48S41S3	75	81	70	68	66	61	58	58	72	19.0	
TCHD60S41S3	73	81	71	67	66	61	58	59	72	19.2	

Rated in accordance with ARI Standard 270

MOUNTING HOLE GRAPHIC

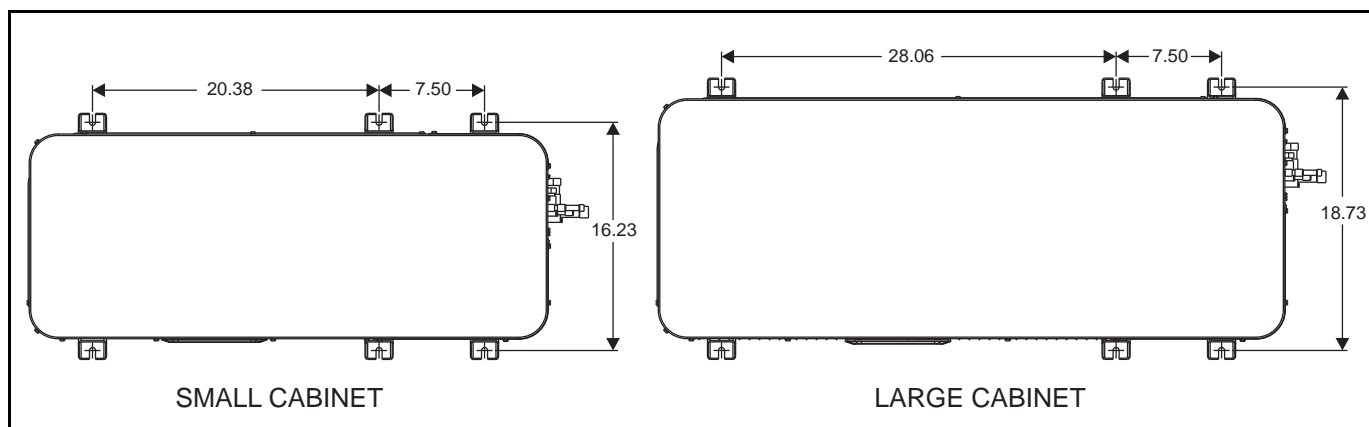

TYPICAL INSTALLATION

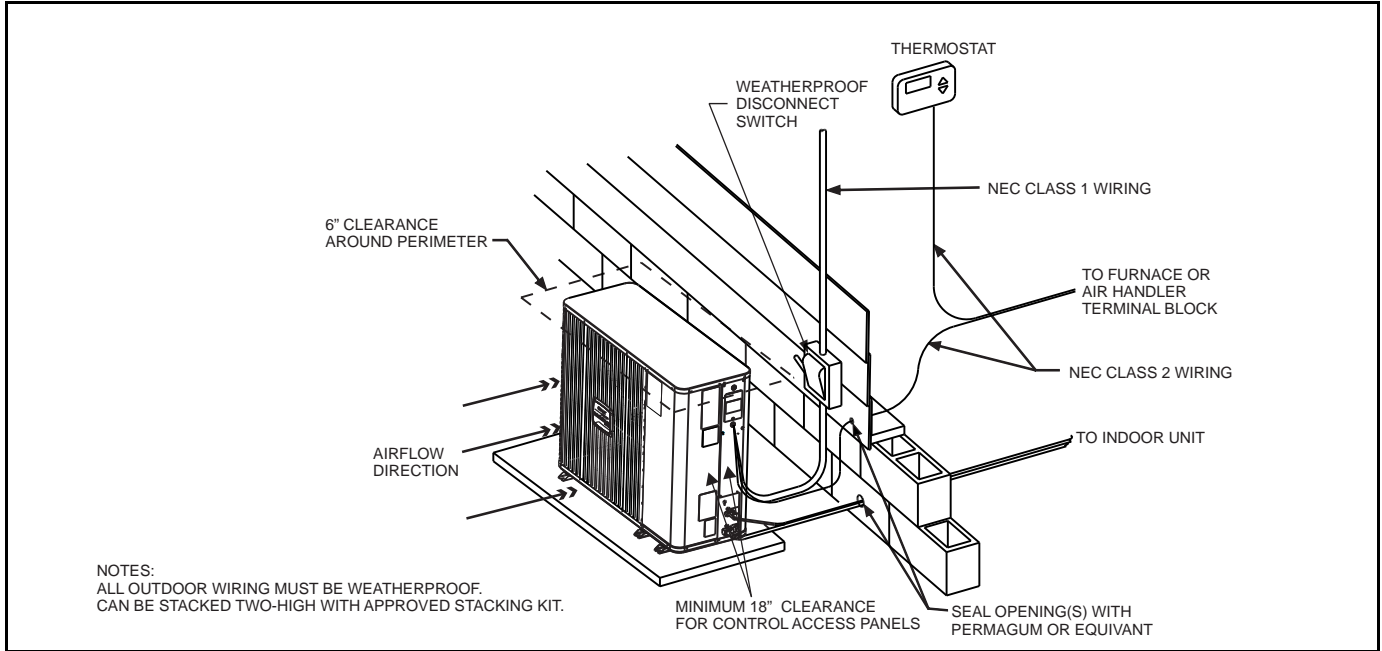

TYPICAL FIELD WIRING

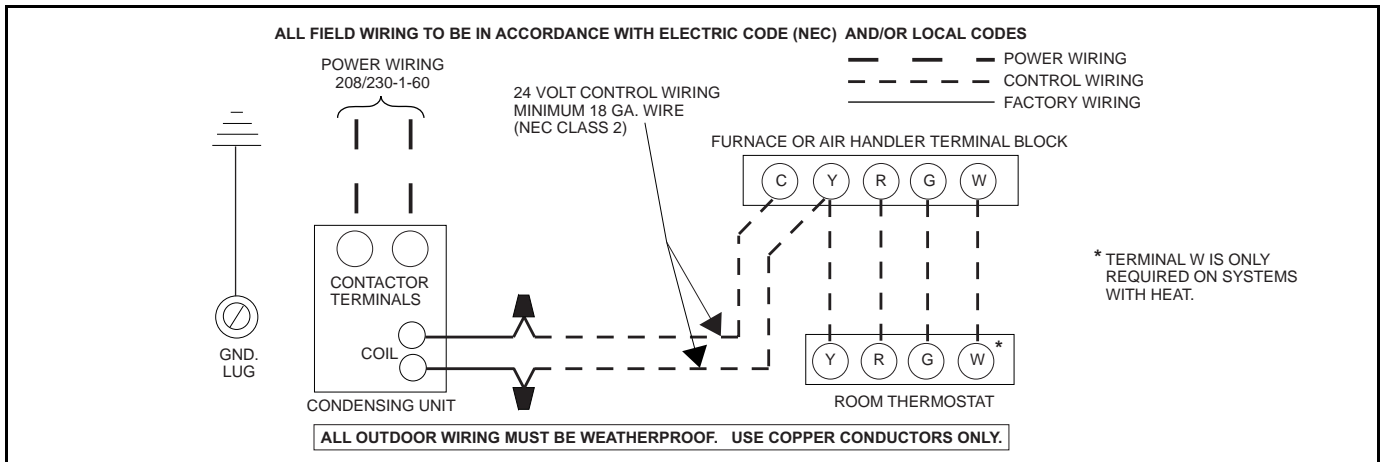

COOLING PERFORMANCE DATA																
AIR CONDITIONER MODEL NO.		TCHD18S41S3														
INDOOR COIL MODEL NO.		FC/MC/PC24														
AIR TEMP. ENTER- ING OUTDOOR UNIT (°F)	IDCFM	450					600					750				
	ID DB (°F)	80	80	75	80	80	80	80	75	80	80	80	80	75	80	80
	ID WB (°F)	57	62	62	67	72	57	62	62	67	72	57	62	62	67	72
65	T.C.	17.3	18.2	18.6	19.7	21.5	18.9	19.0	19.2	20.6	22.5	20.4	19.7	19.8	21.5	23.4
	S.C.	16.6	14.5	12.6	12.2	9.9	18.0	16.9	14.3	14.2	10.7	19.4	19.3	15.9	16.2	11.6
	KW	1.07	1.08	1.09	1.08	1.07	1.07	1.07	1.09	1.07	1.07	1.07	1.07	1.08	1.07	1.08
75	T.C.	16.2	17.3	17.8	18.9	20.7	17.8	18.2	18.4	19.7	21.5	19.4	19.1	19.0	20.5	22.3
	S.C.	15.7	13.9	12.2	11.8	9.6	17.2	16.4	13.9	13.7	10.5	18.7	18.8	15.6	15.6	11.4
	KW	1.28	1.28	1.28	1.27	1.25	1.27	1.27	1.27	1.26	1.25	1.26	1.26	1.26	1.27	1.26
85	T.C.	15.1	16.5	16.9	18.1	20.0	16.7	17.5	17.6	18.9	20.5	18.3	18.5	18.2	19.6	21.1
	S.C.	14.8	13.3	11.8	11.4	9.3	16.4	15.8	13.5	13.1	10.2	18.0	18.4	15.3	14.9	11.2
	KW	1.48	1.48	1.47	1.46	1.44	1.46	1.46	1.46	1.45	1.43	1.44	1.44	1.46	1.44	1.43
95	T.C.	14.0	15.7	16.1	17.3	19.2	15.6	16.8	16.8	18.0	19.6	17.3	18.0	17.4	18.7	19.9
	S.C.	14.0	12.7	11.3	11.0	8.9	15.6	15.3	13.1	12.6	10.0	17.3	17.9	14.9	14.2	11.0
	KW	1.68	1.68	1.66	1.64	1.62	1.65	1.66	1.65	1.64	1.61	1.63	1.63	1.64	1.63	1.61
105	T.C.	13.4	14.5	14.9	16.0	18.1	14.8	15.6	15.6	16.8	18.5	16.3	16.7	16.2	17.6	18.9
	S.C.	13.3	12.2	10.7	10.4	8.5	14.8	14.5	12.4	12.0	9.5	16.3	16.7	14.1	13.7	10.5
	KW	2.16	2.12	2.11	2.12	1.93	2.08	2.06	2.07	2.04	1.92	1.99	1.99	2.02	1.95	1.91
115	T.C.	12.7	13.5	13.7	14.7	16.9	14.0	14.5	14.4	15.6	17.4	15.3	15.6	15.1	16.5	17.9
	S.C.	12.6	11.6	10.0	9.8	8.0	14.0	13.6	11.6	11.5	9.0	15.3	15.6	13.2	13.2	10.0
	KW	2.63	2.54	2.55	2.58	2.23	2.48	2.44	2.47	2.42	2.21	2.34	2.34	2.40	2.27	2.20
125	T.C.	12.1	12.4	12.6	13.4	15.8	13.2	13.4	13.2	14.4	16.3	14.3	14.4	13.9	15.5	16.8
	S.C.	12.0	11.1	9.4	9.2	7.6	13.1	12.8	10.9	10.9	8.5	14.3	14.4	12.4	12.7	9.5
	KW	3.10	2.97	3.00	3.04	2.53	2.89	2.83	2.88	2.81	2.51	2.69	2.68	2.77	2.58	2.49

NOTE: ALL CAPACITIES INCLUDE INDOOR FAN HEAT. KW VALUES ARE FOR THE SYSTEM (OUTDOOR + INDOOR).

Blue shaded cells are AHRI conditions. Green shaded cells are ACCA (TVA) conditions.

Multipliers for determining the performance with other indoor sections.

NOTE: For dry bulb temperatures different than those listed (between 73-87 °F), sensible capacity increases by 1060 BTUH per 1000 CFM per degree above the listed temperature and decreases by 1060 BTUH per 1000 CFM per degree below the listed temperature.

Air Handlers	Coils	T.C.	S.C.	KW
–	FC/MC/PC24	1.00	1.00	1.00
–	FC/MC/PC32	1.01	1.00	1.00
–	FC/MC/PC35	1.01	1.00	1.00
–	FC/MC/PC37	1.02	1.01	1.00
–	HD24	1.04	1.02	1.01
–	UC24	1.00	0.99	1.00
AHE18B	–	1.01	1.02	0.92
AHE24B	–	1.02	1.03	0.91
AHE30B	–	1.02	1.03	0.91
AHE36C	–	1.08	1.16	0.93
AHR18B	–	0.99	1.02	0.99
AHV18B	–	1.00	1.01	0.96
AHV24B	–	1.01	1.02	0.95
AHV30B	–	1.02	1.10	0.96
AHV36C	–	1.03	1.09	0.95
MV12B	FC/MC24B	1.02	1.02	0.93
MV12B	FC/MC35B	1.02	1.04	0.93
MX12BN21	FC/MC18B	1.00	1.01	0.96
MX12BN21	FC/MC24B	1.02	1.03	0.94
MX12BN21	FC/MC35B	1.02	1.04	0.94
MX16CN21	FC/MC35C	1.01	1.02	1.03

Furnaces	Coils	T.C.	S.C.	KW
T*(8,L)C*A12	FC/MC/PC18A	1.01	1.10	0.92
T*(8,L)C*A12	FC/MC/PC24A	1.03	1.06	0.93
T*(8,L)C*A12	FC/MC/PC32A	1.02	1.04	0.92
T*(8,L)C*A12	FC/MC/PC37A	1.04	1.07	0.93
T*(8,L)C*A12	HD24	1.06	1.10	0.93
T*(8,L)C*A12	HD36	1.03	1.02	0.92
T*(8,L)C*A12	UC18A	1.01	1.11	0.92
T*(8,L)C*A12	UC24A	1.03	1.06	0.93
T*(8,L)C*B12	FC/MC/PC18B	0.99	1.09	0.91
T*(8,L)C*B12	FC/MC/PC24B	1.02	1.03	0.91
T*(8,L)C*B12	FC/MC/PC35B	1.03	1.06	0.92
T*(8,L)C*B12	HD24	1.06	1.06	0.91
T*(8,L)C*B12	HD36	1.03	1.02	0.92
T*(8,L)C*B12	UC18B	1.00	1.10	0.91
T*(8,L)C*B12	UC24B	1.02	1.04	0.90
T*(8,L)C*C16	FC/MC/PC35C	1.03	1.06	0.91
T*(8,L)C*C16	HD36	1.03	1.02	0.91
T*(8,L)V*A12	FC/MC/PC24A	1.03	1.06	0.93
T*(8,L)V*A12	FC/MC/PC32A	1.02	1.04	0.92
T*(8,L)V*A12	FC/MC/PC37A	1.04	1.07	0.93
T*(8,L)V*A12	HD24	1.06	1.10	0.93
T*(8,L)V*A12	HD36	1.03	1.02	0.92
T*(8,L)V*A12	UC24A	1.03	1.06	0.93
T*(8,L)V*B12	FC/MC/PC24B	1.02	1.03	0.91
T*(8,L)V*B12	FC/MC/PC35B	1.03	1.06	0.92
T*(8,L)V*B12	HD24	1.06	1.06	0.91
T*(8,L)V*B12	HD36	1.03	1.02	0.92
T*(8,L)V*B12	UC24B	1.02	1.04	0.90

Furnaces	Coils	T.C.	S.C.	KW
T*(8,L)V*C16	FC/MC/PC35C	1.03	1.06	0.91
T*(8,L)V*C16	HD36	1.03	1.02	0.91
T*9(C,V)*B12	FC/MC/PC24B	1.03	1.06	0.92
T*9(C,V)*B12	FC/MC/PC35B	1.02	1.02	0.91
T*9(C,V)*B12	HD24	1.07	1.10	0.92
T*9(C,V)*B12	HD36	1.03	1.02	0.92
T*9(C,V)*B12	UC24B	1.03	1.06	0.91
T*9(C,V)*C16	FC/MC/PC35C	1.03	1.06	0.92
T*9(C,V)*C16	HD36	1.03	1.02	0.91
T*9V*A10	FC/MC/PC18A	0.99	0.98	0.95
T*9V*A10	FC/MC/PC24A	1.02	1.02	0.95
T*9V*A10	FC/MC/PC32A	1.01	1.02	0.95
T*9V*A10	FC/MC/PC37A	1.03	1.02	0.96
TM8X060A12MP11	FC/MC/PC18A	1.00	1.00	0.98
TM8X060A12MP11	FC/MC/PC24A	1.02	1.03	0.95
TM8X060A12MP11	FC/MC/PC32A	1.02	1.03	0.95
TM8X060A12MP11	FC/MC/PC37A	1.03	1.04	0.99
TM8X060A12MP11	UC18A	1.01	1.01	0.98
TM8X060A12MP11	UC24A	1.03	1.03	0.95
TM8X080B12MP11	FC/MC/PC18B	0.99	1.00	0.97
TM8X080B12MP11	FC/MC/PC24B	1.02	1.02	0.95
TM8X080B12MP11	FC/MC/PC35B	1.02	1.03	0.98
TM8X080B12MP11	UC18B	1.01	1.01	0.98
TM8X080B12MP11	UC24B	1.02	1.02	0.95
TM8X080C16MP11	FC/MC/PC35C	1.02	1.03	0.98
TM8X100C16MP11	FC/MC/PC35C	1.02	1.03	0.98
TM9E040A10MP11	FC/MC/PC18A	0.98	0.98	0.99
TM9E040A10MP11	FC/MC/PC24A	1.01	1.01	1.01
TM9E040A10MP11	FC/MC/PC32A	1.01	1.02	1.00
TM9E040A10MP11	FC/MC/PC37A	1.02	1.02	1.00
TM9E060B12MP11	FC/MC/PC18B	0.99	1.00	0.99
TM9E060B12MP11	FC/MC/PC24B	1.02	1.02	0.96
TM9E060B12MP11	FC/MC/PC35B	1.02	1.03	0.99
TM9E060B12MP11	UC18B	1.01	1.00	0.98
TM9E060B12MP11	UC24B	1.02	1.02	0.96
TM9E080B12MP11	FC/MC/PC18B	0.99	1.00	0.99
TM9E080B12MP11	FC/MC/PC24B	1.02	1.02	0.96
TM9E080B12MP11	FC/MC/PC35B	1.02	1.03	0.99
TM9E080B12MP11	UC18B	1.01	1.00	0.98
TM9E080B12MP11	UC24B	1.02	1.02	0.96
TM9E080C16MP11	FC/MC/PC35C	1.02	1.04	0.96
TM9E100C16MP11	FC/MC/PC35C	1.02	1.04	0.96
TM9X040A10MP11	FC/MC/PC18A	0.98	0.98	0.99
TM9X040A10MP11	FC/MC/PC24A	1.01	1.01	1.01
TM9X040A10MP11	FC/MC/PC32A	1.01	1.02	1.00
TM9X040A10MP11	FC/MC/PC37A	1.02	1.02	1.00

Furnaces	Coils	T.C.	S.C.	KW
TM9X060B12MP11	FC/MC/PC18B	0.99	1.00	0.99
TM9X060B12MP11	FC/MC/PC24B	1.02	1.02	0.96
TM9X060B12MP11	FC/MC/PC35B	1.02	1.03	0.99
TM9X060B12MP11	UC18B	1.01	1.00	0.98
TM9X060B12MP11	UC24B	1.02	1.02	0.96
TM9X080B12MP11	FC/MC/PC18B	0.99	1.00	0.99
TM9X080B12MP11	FC/MC/PC24B	1.02	1.02	0.96
TM9X080B12MP11	FC/MC/PC35B	1.02	1.03	0.99
TM9X080B12MP11	UC18B	1.01	1.00	0.98
TM9X080B12MP11	UC24B	1.02	1.02	0.96
TM9X080C16MP11	FC/MC/PC35C	1.02	1.04	0.96
TM9X100C16MP11	FC/MC/PC35C	1.02	1.04	0.96
TMLX060A12MP11	FC/MC/PC18A	1.00	1.00	0.98
TMLX060A12MP11	FC/MC/PC24A	1.02	1.03	0.95
TMLX060A12MP11	FC/MC/PC32A	1.02	1.03	0.95
TMLX060A12MP11	FC/MC/PC37A	1.03	1.04	0.99
TMLX060A12MP11	UC18A	1.01	1.01	0.98
TMLX060A12MP11	UC24A	1.03	1.03	0.95
TMLX080B12MP11	FC/MC/PC18B	0.99	1.00	0.97
TMLX080B12MP11	FC/MC/PC24B	1.02	1.02	0.95
TMLX080B12MP11	FC/MC/PC35B	1.02	1.03	0.98
TMLX080B12MP11	UC18B	1.01	1.01	0.98
TMLX080B12MP11	UC24B	1.02	1.02	0.95
TMLX080C16MP11	FC/MC/PC35C	1.02	1.03	0.98
TMLX100C16MP11	FC/MC/PC35C	1.02	1.03	0.98
Y*(8,L)C*A12	FC/MC/PC24A	1.03	1.06	0.93
Y*(8,L)C*A12	FC/MC/PC32A	1.02	1.04	0.92
Y*(8,L)C*A12	FC/MC/PC37A	1.04	1.07	0.93
Y*(8,L)C*A12	HD24	1.06	1.10	0.93
Y*(8,L)C*A12	HD36	1.03	1.02	0.92
Y*(8,L)C*A12	UC24A	1.03	1.06	0.93
Y*(8,L)C*B12	FC/MC/PC24B	1.02	1.03	0.91
Y*(8,L)C*B12	FC/MC/PC35B	1.03	1.06	0.92
Y*(8,L)C*B12	HD24	1.06	1.06	0.91
Y*(8,L)C*B12	HD36	1.03	1.02	0.92
Y*(8,L)C*B12	UC24B	1.02	1.04	0.90
Y*(8,L)C*C16	FC/MC/PC35C	1.03	1.06	0.91
Y*(8,L)C*C16	HD36	1.03	1.02	0.91
Y*9C*B12	FC/MC/PC24B	1.03	1.06	0.92
Y*9C*B12	FC/MC/PC35B	1.02	1.02	0.91
Y*9C*B12	HD24	1.07	1.10	0.92
Y*9C*B12	HD36	1.03	1.02	0.92
Y*9C*B12	UC24B	1.03	1.06	0.91
Y*9C*C16	FC/MC/PC35C	1.03	1.06	0.92
Y*9C*C16	HD36	1.03	1.02	0.91

COOLING PERFORMANCE DATA																
AIR CONDITIONER MODEL NO.		TCHD24S41S4														
INDOOR COIL MODEL NO.		FC/MC/PC24														
AIR TEMP. ENTER- ING OUTDOOR UNIT (°F)	IDCFM	600					800					1000				
	ID DB (°F)	80	80	75	80	80	80	80	75	80	80	80	80	75	80	80
	ID WB (°F)	57	62	62	67	72	57	62	62	67	72	57	62	62	67	72
65	T.C.	20.4	23.2	23.7	25.5	27.6	22.5	24.3	24.8	26.7	28.7	24.7	25.4	25.8	27.9	29.8
	S.C.	20.0	18.3	15.9	15.7	12.2	21.9	20.8	17.9	17.8	13.4	23.8	23.3	20.0	19.9	14.6
	KW	1.43	1.43	1.44	1.44	1.44	1.51	1.52	1.51	1.50	1.51	1.59	1.60	1.58	1.57	1.59
75	T.C.	20.1	22.2	22.7	24.6	26.7	22.0	23.4	23.7	25.6	27.8	24.0	24.5	24.7	26.6	28.9
	S.C.	19.6	17.9	15.5	15.3	11.9	21.4	20.5	17.6	17.2	13.2	23.2	23.1	19.7	19.2	14.5
	KW	1.62	1.62	1.61	1.61	1.61	1.69	1.70	1.68	1.68	1.69	1.76	1.77	1.75	1.75	1.76
85	T.C.	19.7	21.3	21.7	23.6	25.8	21.5	22.4	22.6	24.5	26.9	23.3	23.6	23.5	25.4	27.9
	S.C.	19.1	17.5	15.0	14.8	11.6	20.8	20.2	17.2	16.7	13.0	22.6	22.9	19.4	18.5	14.3
	KW	1.81	1.81	1.78	1.78	1.78	1.87	1.88	1.86	1.86	1.86	1.94	1.94	1.93	1.93	1.94
95	T.C.	19.4	20.4	20.7	22.7	25.0	21.0	21.5	21.5	23.4	25.9	22.6	22.7	22.4	24.1	26.9
	S.C.	18.7	17.1	14.6	14.4	11.4	20.3	19.9	16.8	16.1	12.8	21.9	22.6	19.1	17.8	14.2
	KW	2.00	2.00	1.96	1.96	1.96	2.06	2.06	2.03	2.03	2.03	2.11	2.11	2.10	2.11	2.11
105	T.C.	18.5	19.2	19.4	21.3	23.5	20.0	20.4	20.2	21.9	24.4	21.4	21.6	21.0	22.6	25.3
	S.C.	17.8	16.6	14.0	13.8	10.8	19.2	18.9	16.2	15.6	12.2	20.7	21.2	18.5	17.4	13.6
	KW	2.31	2.30	2.28	2.27	2.25	2.35	2.34	2.34	2.34	2.32	2.40	2.39	2.40	2.40	2.38
115	T.C.	17.6	18.1	18.1	19.8	22.0	18.9	19.3	18.9	20.5	22.9	20.3	20.5	19.7	21.2	23.7
	S.C.	16.9	16.1	13.5	13.1	10.3	18.2	18.0	15.7	15.1	11.7	19.6	19.8	17.8	17.0	13.1
	KW	2.60	2.58	2.58	2.58	2.53	2.64	2.63	2.64	2.63	2.59	2.68	2.67	2.69	2.69	2.65
125	T.C.	16.7	17.0	16.9	18.4	20.6	17.9	18.2	17.6	19.1	21.4	19.1	19.4	18.3	19.8	22.1
	S.C.	16.0	15.7	12.9	12.5	9.8	17.2	17.0	15.1	14.5	11.2	18.4	18.4	17.2	16.5	12.5
	KW	2.90	2.87	2.89	2.88	2.81	2.93	2.91	2.94	2.93	2.86	2.96	2.94	2.98	2.97	2.91

NOTE: ALL CAPACITIES INCLUDE INDOOR FAN HEAT. KW VALUES ARE FOR THE SYSTEM (OUTDOOR + INDOOR).

Blue shaded cells are AHRI conditions. Green shaded cells are ACCA (TVA) conditions.

Multipliers for determining the performance with other indoor sections.

NOTE: For dry bulb temperatures different than those listed (between 73-87 °F), sensible capacity increases by 1060 BTUH per 1000 CFM per degree above the listed temperature and decreases by 1060 BTUH per 1000 CFM per degree below the listed temperature.

Air Handlers	Coils	T.C.	S.C.	KW
–	FC/MC/PC24	1.00	1.00	1.00
–	FC/MC/PC32	1.01	1.01	1.01
–	FC/MC/PC35	1.01	1.01	1.01
–	FC/MC/PC37	1.02	1.04	1.02
–	FC/MC/PC43	1.02	1.04	1.02
–	FC/MC/PC48	1.03	1.04	1.00
–	HD24	1.02	1.02	1.00
–	HD36	0.99	0.98	1.01
–	UC24	1.01	1.01	1.01
–	UC48	1.00	1.02	1.00
AHE24B	–	1.03	1.05	0.91
AHE30B	–	1.03	1.05	0.91
AHE36C	–	1.04	1.10	0.89
AHE42D	–	1.04	1.07	0.89
AHR24B	–	1.00	0.99	0.96
AHV24B	–	1.02	1.01	0.92

Air Handlers	Coils	T.C.	S.C.	KW
AHV30B	–	1.01	1.01	0.93
AHV36C	–	1.03	1.06	0.90
MV12B	FC/MC24B	1.03	1.06	0.90
MV12B	FC/MC35B	1.03	1.04	0.91
MV12B	FC/MC43B	1.04	1.07	0.92
MV12D	FC/MC48D	1.04	1.09	0.89
MX12BN21	FC/MC24B	1.03	1.06	0.91
MX12BN21	FC/MC35B	1.03	1.04	0.93
MX12BN21	FC/MC43B	1.04	1.07	0.92
MX12DN21	FC/MC48D	1.04	1.05	0.89
MX16CN21	FC/MC35C	1.03	1.04	0.94
MX16CN21	FC/MC43C	1.03	1.06	0.93
MX16CN21	FC/MC48C	1.04	1.06	0.92

Furnaces	Coils	T.C.	S.C.	KW
T*(8,L)C*A12	FC/MC/PC24A	1.02	1.02	0.92
T*(8,L)C*A12	FC/MC/PC32A	1.03	1.04	0.93
T*(8,L)C*A12	FC/MC/PC37A	1.04	1.07	0.92
T*(8,L)C*A12	HD24	1.04	1.04	0.92
T*(8,L)C*A12	HD36	1.01	1.00	0.93
T*(8,L)C*A12	UC24A	1.03	1.04	0.93
T*(8,L)C*B12	FC/MC/PC24B	1.02	1.02	0.90
T*(8,L)C*B12	FC/MC/PC35B	1.03	1.04	0.91
T*(8,L)C*B12	FC/MC/PC43B	1.04	1.07	0.92
T*(8,L)C*B12	HD24	1.04	1.04	0.91
T*(8,L)C*B12	HD36	1.00	0.99	0.92
T*(8,L)C*B12	UC24B	1.03	1.04	0.91
T*(8,L)C*C16	FC/MC/PC35C	1.03	1.04	0.91
T*(8,L)C*C16	FC/MC/PC43C	1.04	1.07	0.91
T*(8,L)C*C16	FC/MC/PC48C	1.04	1.05	0.89
T*(8,L)C*C16	HD36	1.03	1.03	0.91
T*(8,L)C*C16	UC48C	1.03	1.05	0.90
T*(8,L)C*C20	FC/MC/PC35C	1.03	1.04	0.90
T*(8,L)C*C20	FC/MC/PC43C	1.03	1.04	0.90
T*(8,L)C*C20	FC/MC/PC48C	1.04	1.04	0.91
T*(8,L)C*C20	HD36	1.01	0.99	0.89
T*(8,L)C*C20	UC48C	1.03	1.03	0.91
T*(8,L)V*A12	FC/MC/PC24A	1.02	1.02	0.92
T*(8,L)V*A12	FC/MC/PC32A	1.03	1.04	0.93
T*(8,L)V*A12	FC/MC/PC37A	1.04	1.07	0.92
T*(8,L)V*A12	HD24	1.04	1.04	0.92
T*(8,L)V*A12	HD36	1.01	1.00	0.93
T*(8,L)V*A12	UC24A	1.03	1.04	0.93
T*(8,L)V*B12	FC/MC/PC24B	1.02	1.02	0.90
T*(8,L)V*B12	FC/MC/PC35B	1.03	1.04	0.91
T*(8,L)V*B12	FC/MC/PC43B	1.04	1.07	0.92
T*(8,L)V*B12	HD24	1.04	1.04	0.91
T*(8,L)V*B12	HD36	1.00	0.99	0.92
T*(8,L)V*B12	UC24B	1.03	1.04	0.91
T*(8,L)V*C16	FC/MC/PC35C	1.03	1.04	0.91
T*(8,L)V*C16	FC/MC/PC43C	1.04	1.07	0.91
T*(8,L)V*C16	FC/MC/PC48C	1.04	1.05	0.89
T*(8,L)V*C16	HD36	1.03	1.03	0.91
T*(8,L)V*C16	UC48C	1.03	1.05	0.90
T*(8,L)V*C20	FC/MC/PC35C	1.03	1.04	0.90
T*(8,L)V*C20	FC/MC/PC43C	1.03	1.04	0.90
T*(8,L)V*C20	FC/MC/PC48C	1.04	1.04	0.91
T*(8,L)V*C20	HD36	1.01	0.99	0.89
T*(8,L)V*C20	UC48C	1.03	1.03	0.91
T*9(C,V)*B12	FC/MC/PC24B	1.03	1.05	0.93
T*9(C,V)*B12	FC/MC/PC35B	1.03	1.04	0.93
T*9(C,V)*B12	FC/MC/PC43B	1.04	1.07	0.92
T*9(C,V)*B12	HD24	1.04	1.04	0.92
T*9(C,V)*B12	HD36	1.01	1.00	0.93
T*9(C,V)*B12	UC24B	1.03	1.04	0.93
T*9(C,V)*C16	FC/MC/PC35C	1.04	1.10	0.92
T*9(C,V)*C16	FC/MC/PC43C	1.04	1.07	0.92
T*9(C,V)*C16	FC/MC/PC48C	1.04	1.10	0.91
T*9(C,V)*C16	HD36	1.02	1.00	0.92
T*9(C,V)*C16	UC48C	1.04	1.12	0.92
T*9(C,V)*C20	FC/MC/PC35C	1.03	1.04	0.91
T*9(C,V)*C20	FC/MC/PC43C	1.04	1.12	0.91
T*9(C,V)*C20	FC/MC/PC48C	1.04	1.10	0.91
T*9(C,V)*C20	HD36	1.01	0.99	0.91
T*9(C,V)*C20	UC48C	1.04	1.12	0.92
T*9V*A10	FC/MC/PC24A	1.01	1.01	0.97
T*9V*A10	FC/MC/PC32A	1.02	1.02	0.95

Furnaces	Coils	T.C.	S.C.	KW
T*9V*A10	FC/MC/PC37A	1.03	1.06	0.96
TM8X060A12MP11	FC/MC/PC24A	1.01	1.01	0.91
TM8X060A12MP11	FC/MC/PC32A	1.03	1.04	0.93
TM8X060A12MP11	FC/MC/PC37A	1.03	1.06	0.93
TM8X060A12MP11	HD24	1.04	1.04	0.89
TM8X060A12MP11	HD36	1.02	1.00	0.92
TM8X060A12MP11	UC24A	1.02	1.02	0.92
TM8X080B12MP11	FC/MC/PC24B	1.02	1.02	0.92
TM8X080B12MP11	FC/MC/PC35B	1.03	1.04	0.91
TM8X080B12MP11	FC/MC/PC43B	1.04	1.07	0.92
TM8X080B12MP11	HD24	1.04	1.08	0.89
TM8X080B12MP11	HD36	1.03	1.04	0.90
TM8X080B12MP11	UC24B	1.03	1.04	0.91
TM8X080C16MP11	FC/MC/PC35C	1.02	1.03	0.95
TM8X080C16MP11	FC/MC/PC43C	1.03	1.06	0.95
TM8X080C16MP11	FC/MC/PC48C	1.04	1.06	0.96
TM8X080C16MP11	HD36	1.03	1.04	0.90
TM8X080C16MP11	UC48C	1.02	1.04	0.95
TM8X100C16MP11	FC/MC/PC35C	1.02	1.03	0.95
TM8X100C16MP11	FC/MC/PC43C	1.03	1.06	0.95
TM8X100C16MP11	FC/MC/PC48C	1.04	1.06	0.96
TM8X100C16MP11	HD36	1.03	1.04	0.90
TM8X100C16MP11	UC48C	1.02	1.04	0.95
TM8X100C20MP11	FC/MC/PC35C	1.02	1.02	0.97
TM8X100C20MP11	FC/MC/PC43C	1.03	1.06	0.96
TM8X100C20MP11	FC/MC/PC48C	1.04	1.05	0.96
TM8X100C20MP11	HD36	1.03	1.04	0.90
TM8X100C20MP11	UC48C	1.02	1.03	0.97
TM8X120C20MP11	FC/MC/PC35C	1.02	1.02	0.97
TM8X120C20MP11	FC/MC/PC43C	1.03	1.06	0.96
TM8X120C20MP11	FC/MC/PC48C	1.04	1.05	0.96
TM8X120C20MP11	HD36	1.03	1.04	0.90
TM8X120C20MP11	UC48C	1.02	1.03	0.97
TM9E040A10MP11	FC/MC/PC24A	1.02	1.04	1.00
TM9E040A10MP11	FC/MC/PC32A	1.01	1.02	0.99
TM9E040A10MP11	FC/MC/PC37A	1.03	1.05	0.98
TM9E040A10MP11	UC24A	1.02	1.02	1.00
TM9E060B12MP11	FC/MC/PC24B	1.03	1.04	0.96
TM9E060B12MP11	FC/MC/PC35B	1.02	1.03	0.95
TM9E060B12MP11	FC/MC/PC43B	1.03	1.06	0.95
TM9E060B12MP11	HD24	1.04	1.04	0.89
TM9E060B12MP11	HD36	1.02	1.01	0.90
TM9E060B12MP11	UC24B	1.02	1.02	0.95
TM9E080B12MP11	FC/MC/PC24B	1.03	1.04	0.96
TM9E080B12MP11	FC/MC/PC35B	1.02	1.03	0.95
TM9E080B12MP11	FC/MC/PC43B	1.03	1.06	0.95
TM9E080B12MP11	HD24	1.04	1.04	0.89
TM9E080B12MP11	HD36	1.02	1.01	0.90
TM9E080B12MP11	UC24B	1.02	1.02	0.95
TM9E080C16MP11	FC/MC/PC24B	1.03	1.04	0.96
TM9E080C16MP11	FC/MC/PC35C	1.02	1.02	0.97
TM9E080C16MP11	FC/MC/PC43C	1.03	1.05	0.98
TM9E080C16MP11	FC/MC/PC48C	1.03	1.05	0.97
TM9E080C16MP11	HD36	1.00	0.98	0.88
TM9E080C16MP11	UC48C	1.02	1.03	0.97
TM9E100C16MP11	FC/MC/PC35C	1.02	1.02	0.97
TM9E100C16MP11	FC/MC/PC43C	1.03	1.05	0.98
TM9E100C16MP11	FC/MC/PC48C	1.03	1.05	0.97
TM9E100C16MP11	HD36	1.00	0.98	0.88
TM9E100C16MP11	UC48C	1.02	1.03	0.97
TM9E100C20MP11	FC/MC/PC35C	1.03	1.03	0.94
TM9E100C20MP11	FC/MC/PC43C	1.03	1.06	0.93
TM9E100C20MP11	FC/MC/PC48C	1.04	1.06	0.92

Furnaces	Coils	T.C.	S.C.	KW
TM9E100C20MP11	HD36	1.03	1.03	0.91
TM9E100C20MP11	UC48C	1.03	1.04	0.94
TM9E120D20MP11	FC/MC/PC48D	1.04	1.06	0.92
TM9E120D20MP11	UC48D	1.03	1.04	0.93
TM9X040A10MP11	FC/MC/PC24A	1.02	1.04	1.00
TM9X040A10MP11	FC/MC/PC32A	1.01	1.02	0.99
TM9X040A10MP11	FC/MC/PC37A	1.03	1.05	0.98
TM9X040A10MP11	UC24A	1.02	1.02	1.00
TM9X060B12MP11	FC/MC/PC24B	1.03	1.04	0.96
TM9X060B12MP11	FC/MC/PC35B	1.02	1.03	0.95
TM9X060B12MP11	FC/MC/PC43B	1.03	1.06	0.95
TM9X060B12MP11	HD24	1.04	1.04	0.89
TM9X060B12MP11	HD36	1.02	1.01	0.90
TM9X060B12MP11	UC24B	1.02	1.02	0.95
TM9X080B12MP11	FC/MC/PC24B	1.03	1.04	0.96
TM9X080B12MP11	FC/MC/PC35B	1.02	1.03	0.95
TM9X080B12MP11	FC/MC/PC43B	1.03	1.06	0.95
TM9X080B12MP11	HD24	1.04	1.04	0.89
TM9X080B12MP11	HD36	1.02	1.01	0.90
TM9X080B12MP11	UC24B	1.02	1.02	0.95
TM9X080C16MP11	FC/MC/PC35C	1.02	1.02	0.97
TM9X080C16MP11	FC/MC/PC43C	1.03	1.05	0.98
TM9X080C16MP11	FC/MC/PC48C	1.03	1.05	0.97
TM9X080C16MP11	HD36	1.00	0.98	0.88
TM9X080C16MP11	UC48C	1.02	1.03	0.97
TM9X100C16MP11	FC/MC/PC35C	1.02	1.02	0.97
TM9X100C16MP11	FC/MC/PC43C	1.03	1.05	0.98
TM9X100C16MP11	FC/MC/PC48C	1.03	1.05	0.97
TM9X100C16MP11	HD36	1.00	0.98	0.88
TM9X100C16MP11	UC48C	1.02	1.03	0.97
TM9X100C20MP11	FC/MC/PC35C	1.03	1.03	0.94
TM9X100C20MP11	FC/MC/PC43C	1.03	1.06	0.93
TM9X100C20MP11	FC/MC/PC48C	1.04	1.06	0.92
TM9X100C20MP11	HD36	1.03	1.03	0.91
TM9X100C20MP11	UC48C	1.03	1.04	0.94
TM9X120D20MP11	FC/MC/PC48D	1.04	1.06	0.92
TM9X120D20MP11	UC48D	1.03	1.04	0.93
TMLX060A12MP11	FC/MC/PC24A	1.01	1.01	0.91
TMLX060A12MP11	FC/MC/PC32A	1.03	1.04	0.93
TMLX060A12MP11	FC/MC/PC37A	1.03	1.06	0.93
TMLX060A12MP11	HD24	1.04	1.04	0.89
TMLX060A12MP11	HD36	1.02	1.00	0.92
TMLX060A12MP11	UC24A	1.02	1.02	0.92
TMLX080B12MP11	FC/MC/PC24B	1.02	1.02	0.92
TMLX080B12MP11	FC/MC/PC35B	1.03	1.04	0.91
TMLX080B12MP11	FC/MC/PC43B	1.04	1.07	0.92
TMLX080B12MP11	HD24	1.04	1.08	0.89
TMLX080B12MP11	HD36	1.03	1.04	0.90
TMLX080B12MP11	UC24B	1.03	1.04	0.91
TMLX080C16MP11	FC/MC/PC35C	1.02	1.03	0.95
TMLX080C16MP11	FC/MC/PC43C	1.03	1.06	0.95
TMLX080C16MP11	FC/MC/PC48C	1.04	1.06	0.96
TMLX080C16MP11	HD36	1.03	1.04	0.90
TMLX080C16MP11	UC48C	1.02	1.04	0.95

Furnaces	Coils	T.C.	S.C.	KW
TMLX100C16MP11	FC/MC/PC35C	1.02	1.03	0.95
TMLX100C16MP11	FC/MC/PC43C	1.03	1.06	0.95
TMLX100C16MP11	FC/MC/PC48C	1.04	1.06	0.96
TMLX100C16MP11	HD36	1.03	1.04	0.90
TMLX100C16MP11	UC48C	1.02	1.04	0.95
TMLX100C20MP11	FC/MC/PC35C	1.02	1.02	0.97
TMLX100C20MP11	FC/MC/PC43C	1.03	1.06	0.96
TMLX100C20MP11	FC/MC/PC48C	1.04	1.05	0.96
TMLX100C20MP11	HD36	1.03	1.04	0.90
TMLX100C20MP11	UC48C	1.02	1.03	0.97
TMLX120C20MP11	FC/MC/PC35C	1.02	1.02	0.97
TMLX120C20MP11	FC/MC/PC43C	1.03	1.06	0.96
TMLX120C20MP11	FC/MC/PC48C	1.04	1.05	0.96
TMLX120C20MP11	HD36	1.03	1.04	0.90
TMLX120C20MP11	UC48C	1.02	1.03	0.97
Y*(8,L)C*A12	FC/MC/PC24A	1.02	1.02	0.92
Y*(8,L)C*A12	FC/MC/PC32A	1.03	1.04	0.93
Y*(8,L)C*A12	FC/MC/PC37A	1.04	1.07	0.92
Y*(8,L)C*A12	HD24	1.04	1.04	0.92
Y*(8,L)C*A12	HD36	1.01	1.00	0.93
Y*(8,L)C*A12	UC24A	1.03	1.04	0.93
Y*(8,L)C*B12	FC/MC/PC24B	1.02	1.02	0.90
Y*(8,L)C*B12	FC/MC/PC35B	1.03	1.04	0.91
Y*(8,L)C*B12	FC/MC/PC43B	1.04	1.07	0.92
Y*(8,L)C*B12	HD24	1.04	1.04	0.91
Y*(8,L)C*B12	HD36	1.00	0.99	0.92
Y*(8,L)C*B12	UC24B	1.03	1.04	0.91
Y*(8,L)C*C16	FC/MC/PC35C	1.03	1.04	0.91
Y*(8,L)C*C16	FC/MC/PC43C	1.04	1.07	0.91
Y*(8,L)C*C16	FC/MC/PC48C	1.04	1.05	0.89
Y*(8,L)C*C16	HD36	1.03	1.03	0.91
Y*(8,L)C*C16	UC48C	1.03	1.05	0.90
Y*(8,L)C*C20	FC/MC/PC35C	1.03	1.04	0.90
Y*(8,L)C*C20	FC/MC/PC43C	1.03	1.04	0.90
Y*(8,L)C*C20	FC/MC/PC48C	1.04	1.04	0.91
Y*(8,L)C*C20	HD36	1.01	0.99	0.89
Y*(8,L)C*C20	UC48C	1.03	1.03	0.91
Y*9C*B12	FC/MC/PC24B	1.03	1.05	0.93
Y*9C*B12	FC/MC/PC35B	1.03	1.04	0.93
Y*9C*B12	FC/MC/PC43B	1.04	1.07	0.92
Y*9C*B12	HD24	1.04	1.04	0.92
Y*9C*B12	HD36	1.01	1.00	0.93
Y*9C*B12	UC24B	1.03	1.04	0.93
Y*9C*C16	FC/MC/PC35C	1.04	1.10	0.92
Y*9C*C16	FC/MC/PC43C	1.04	1.07	0.92
Y*9C*C16	FC/MC/PC48C	1.04	1.10	0.91
Y*9C*C16	HD36	1.02	1.00	0.92
Y*9C*C16	UC48C	1.04	1.12	0.92
Y*9C*C20	FC/MC/PC35C	1.03	1.04	0.91
Y*9C*C20	FC/MC/PC43C	1.04	1.12	0.91
Y*9C*C20	FC/MC/PC48C	1.04	1.10	0.91
Y*9C*C20	HD36	1.01	0.99	0.91
Y*9C*C20	UC48C	1.04	1.12	0.92

COOLING PERFORMANCE DATA																
AIR CONDITIONER MODEL NO.		TCHD30S41S3														
INDOOR COIL MODEL NO.		FC/MC/PC35														
AIR TEMP. ENTER- ING OUTDOOR UNIT (°F)	IDCFM	800					1000					1200				
	ID DB (°F)	80	80	75	80	80	80	80	75	80	80	80	80	75	80	80
	ID WB (°F)	57	62	62	67	72	57	62	62	67	72	57	62	62	67	72
65	T.C.	27.3	28.7	28.9	30.5	31.8	28.8	29.9	29.8	31.6	33.4	30.3	31.0	30.7	32.8	35.0
	S.C.	26.6	24.5	20.7	20.5	15.9	28.2	27.4	23.2	22.6	17.2	29.7	30.4	25.7	24.7	18.5
	KW	1.61	1.64	1.61	1.64	1.63	1.63	1.63	1.61	1.64	1.64	1.65	1.62	1.61	1.64	1.65
75	T.C.	26.2	27.0	27.1	29.4	31.2	27.8	28.3	28.3	30.4	32.2	29.5	29.5	29.5	31.5	33.2
	S.C.	25.6	23.9	19.9	19.8	15.4	27.2	26.4	22.3	22.0	16.8	28.8	28.9	24.6	24.1	18.1
	KW	1.88	1.88	1.89	1.88	1.86	1.87	1.87	1.88	1.87	1.86	1.87	1.87	1.88	1.87	1.86
85	T.C.	25.1	25.3	25.2	28.3	30.6	26.8	26.7	26.7	29.2	31.0	28.6	28.0	28.3	30.1	31.4
	S.C.	24.5	23.2	19.1	19.2	15.0	26.2	25.3	21.3	21.3	16.3	28.0	27.4	23.6	23.5	17.7
	KW	2.15	2.12	2.18	2.11	2.09	2.12	2.12	2.16	2.10	2.09	2.09	2.12	2.14	2.10	2.08
95	T.C.	23.9	23.7	23.3	27.2	30.0	25.8	25.1	25.2	28.0	29.8	27.8	26.5	27.1	28.8	29.6
	S.C.	23.5	22.6	18.2	18.5	14.5	25.3	24.3	20.4	20.7	15.9	27.1	25.9	22.5	22.9	17.3
	KW	2.41	2.36	2.46	2.34	2.32	2.37	2.36	2.43	2.33	2.31	2.32	2.36	2.41	2.32	2.30
105	T.C.	22.4	22.6	22.2	25.0	27.8	24.3	24.1	23.8	26.1	27.8	26.2	25.6	25.3	27.3	27.9
	S.C.	21.9	21.5	17.6	17.8	13.9	23.7	23.1	19.7	20.0	15.3	25.5	24.8	21.7	22.2	16.7
	KW	2.93	2.96	3.05	2.84	2.70	2.85	2.88	3.01	2.80	2.69	2.76	2.80	2.97	2.76	2.67
115	T.C.	20.9	21.5	21.2	22.9	25.6	22.8	23.1	22.4	24.4	26.0	24.7	24.7	23.5	25.8	26.3
	S.C.	20.5	20.4	17.0	17.1	13.4	22.2	22.0	19.0	19.3	14.7	24.0	23.6	20.9	21.5	16.1
	KW	3.44	3.54	3.61	3.32	3.07	3.31	3.38	3.56	3.25	3.05	3.19	3.22	3.51	3.18	3.03
125	T.C.	19.5	20.4	20.1	20.7	23.4	21.3	22.1	20.9	22.6	24.1	23.2	23.9	21.8	24.4	24.7
	S.C.	19.0	19.3	16.4	16.4	12.8	20.7	20.9	18.3	18.6	14.2	22.4	22.5	20.1	20.8	15.5
	KW	3.94	4.13	4.18	3.81	3.44	3.78	3.88	4.12	3.70	3.42	3.62	3.63	4.06	3.60	3.39

NOTE: ALL CAPACITIES INCLUDE INDOOR FAN HEAT. KW VALUES ARE FOR THE SYSTEM (OUTDOOR + INDOOR).

Blue shaded cells are AHRI conditions. Green shaded cells are ACCA (TVA) conditions.

Multipliers for determining the performance with other indoor sections.

NOTE: For dry bulb temperatures different than those listed (between 73-87 °F), sensible capacity increases by 1060 BTUH per 1000 CFM per degree above the listed temperature and decreases by 1060 BTUH per 1000 CFM per degree below the listed temperature.

Air Handlers	Coils	T.C.	S.C.	KW
-	FC/MC/PC32	1.00	1.00	1.00
-	FC/MC/PC35	1.00	1.00	1.00
-	FC/MC/PC37	1.01	1.02	1.00
-	FC/MC/PC43	1.01	1.02	1.00
-	FC/MC/PC48	1.02	1.03	1.00
-	HD36	0.99	0.96	1.00
-	UC48	0.96	0.96	1.00
AHE30B	-	1.01	1.02	0.94
AHE36C	-	1.04	1.05	0.92
AHE42D	-	1.05	1.07	0.90
AHR30B	-	1.01	1.05	1.01
AHR36B	-	1.02	1.05	1.02
AHV30B	-	1.01	1.00	0.99
AHV36C	-	1.02	1.00	0.94
AHV42D	-	1.06	1.10	0.96

Air Handlers	Coils	T.C.	S.C.	KW
MV12B	FC/MC35B	1.02	1.02	0.93
MV12B	FC/MC43B	1.04	1.04	0.93
MV16C	FC/MC35C	1.02	1.02	0.93
MV16C	FC/MC43C	1.04	1.04	0.92
MV16C	FC/MC48C	1.05	1.05	0.92
MX12BN21	FC/MC35B	1.02	1.03	0.94
MX12BN21	FC/MC43B	1.04	1.05	0.93
MX12DN21	FC/MC48D	1.04	1.04	0.92
MX16CN21	FC/MC35C	1.02	1.03	0.94
MX16CN21	FC/MC43C	1.03	1.03	0.91
MX16CN21	FC/MC48C	1.04	1.04	0.90
MX20DN21	FC/MC48D	1.04	1.05	0.97

Furnaces	Coils	T.C.	S.C.	KW
T*(8,L)C*A12	FC/MC/PC32A	1.00	1.01	0.99
T*(8,L)C*A12	FC/MC/PC37A	1.03	1.04	0.96
T*(8,L)C*A12	HD36	1.00	0.97	0.95
T*(8,L)C*B12	FC/MC/PC35B	1.01	1.02	0.95
T*(8,L)C*B12	FC/MC/PC43B	1.03	1.05	0.94
T*(8,L)C*B12	HD36	1.00	0.98	0.92
T*(8,L)C*C16	FC/MC/PC35C	1.01	1.03	0.93
T*(8,L)C*C16	FC/MC/PC43C	1.04	1.05	0.91
T*(8,L)C*C16	HD36	1.01	0.98	0.93
T*(8,L)C*C20	FC/MC/PC35C	1.03	1.07	0.95
T*(8,L)C*C20	FC/MC/PC43C	1.04	1.05	0.91
T*(8,L)C*C20	HD36	1.01	1.01	0.92
T*(8,L)V*A12	FC/MC/PC32A	1.00	1.01	0.99
T*(8,L)V*A12	FC/MC/PC37A	1.03	1.04	0.96
T*(8,L)V*A12	HD36	1.00	0.97	0.95
T*(8,L)V*B12	FC/MC/PC35B	1.01	1.02	0.95
T*(8,L)V*B12	FC/MC/PC43B	1.03	1.05	0.94
T*(8,L)V*B12	HD36	1.00	0.98	0.92
T*(8,L)V*C16	FC/MC/PC35C	1.01	1.03	0.93
T*(8,L)V*C16	FC/MC/PC43C	1.04	1.05	0.91
T*(8,L)V*C16	HD36	1.01	0.98	0.93
T*(8,L)V*C20	FC/MC/PC35C	1.03	1.07	0.95
T*(8,L)V*C20	FC/MC/PC43C	1.04	1.05	0.91
T*(8,L)V*C20	HD36	1.01	1.01	0.92
T*9(C,V)*B12	FC/MC/PC35B	1.01	1.04	0.97
T*9(C,V)*B12	FC/MC/PC43B	1.03	1.04	0.96
T*9(C,V)*B12	HD36	1.00	0.98	0.93
T*9(C,V)*C16	FC/MC/PC35C	1.01	1.03	0.93
T*9(C,V)*C16	FC/MC/PC43C	1.03	1.04	0.94
T*9(C,V)*C16	HD36	1.01	0.98	0.93
T*9(C,V)*C20	FC/MC/PC35C	1.01	1.03	0.93
T*9(C,V)*C20	FC/MC/PC43C	1.04	1.05	0.92
T*9(C,V)*C20	HD36	1.00	0.98	0.92
TM8X060A12MP11	FC/MC/PC32A	1.00	1.01	1.00
TM8X060A12MP11	FC/MC/PC37A	1.01	1.03	1.00
TM8X080B12MP11	FC/MC/PC35B	1.01	1.00	0.95
TM8X080B12MP11	FC/MC/PC43B	1.04	1.05	0.97
TM8X080C16MP11	FC/MC/PC35C	1.03	1.04	0.95
TM8X080C16MP11	FC/MC/PC43C	1.02	1.03	0.94
TM8X080C16MP11	FC/MC/PC48C	1.03	1.03	0.95
TM8X080C16MP11	FC/MC/PC48D	1.03	1.03	0.95
TM8X080C16MP11	UC48C	1.02	1.04	0.94
TM8X080C16MP11	UC48D	1.02	1.04	0.94
TM8X100C16MP11	FC/MC/PC35C	1.03	1.04	0.95
TM8X100C16MP11	FC/MC/PC43C	1.02	1.03	0.94
TM8X100C16MP11	FC/MC/PC48C	1.03	1.03	0.95
TM8X100C16MP11	FC/MC/PC48D	1.03	1.03	0.95
TM8X100C16MP11	UC48C	1.02	1.04	0.94
TM8X100C16MP11	UC48D	1.02	1.04	0.94
TM8X100C20MP11	FC/MC/PC35C	1.02	1.04	0.94
TM8X100C20MP11	FC/MC/PC43C	1.04	1.06	0.96
TM8X100C20MP11	FC/MC/PC48C	1.04	1.05	0.93
TM8X100C20MP11	FC/MC/PC48D	1.04	1.05	0.96
TM8X100C20MP11	UC48C	1.01	1.03	0.95
TM8X100C20MP11	UC48D	1.01	1.03	0.95
TM8X120C20MP11	FC/MC/PC35C	1.02	1.04	0.94
TM8X120C20MP11	FC/MC/PC43C	1.04	1.06	0.96
TM8X120C20MP11	FC/MC/PC48C	1.04	1.05	0.93
TM8X120C20MP11	FC/MC/PC48D	1.04	1.05	0.96
TM8X120C20MP11	UC48C	1.01	1.03	0.95
TM8X120C20MP11	UC48D	1.01	1.03	0.95
TM9E060B12MP11	FC/MC/PC35B	1.00	1.00	0.95

Furnaces	Coils	T.C.	S.C.	KW
TM9E060B12MP11	FC/MC/PC43B	1.01	1.02	0.97
TM9E080B12MP11	FC/MC/PC35B	1.00	1.00	0.95
TM9E080B12MP11	FC/MC/PC43B	1.01	1.02	0.97
TM9E080C16MP11	FC/MC/PC35C	1.02	1.04	0.94
TM9E080C16MP11	FC/MC/PC43C	1.04	1.05	0.96
TM9E080C16MP11	FC/MC/PC48C	1.04	1.05	0.94
TM9E080C16MP11	FC/MC/PC48D	1.04	1.05	0.96
TM9E080C16MP11	UC48C	1.01	1.03	0.95
TM9E080C16MP11	UC48D	1.01	1.03	0.95
TM9E100C16MP11	FC/MC/PC35C	1.02	1.04	0.94
TM9E100C16MP11	FC/MC/PC43C	1.04	1.05	0.96
TM9E100C16MP11	FC/MC/PC48C	1.04	1.05	0.94
TM9E100C16MP11	FC/MC/PC48D	1.04	1.05	0.96
TM9E100C16MP11	UC48C	1.01	1.03	0.95
TM9E100C16MP11	UC48D	1.01	1.03	0.95
TM9E100C20MP11	FC/MC/PC35C	1.01	1.02	1.01
TM9E100C20MP11	FC/MC/PC43C	1.02	1.04	1.00
TM9E100C20MP11	FC/MC/PC48C	1.02	1.03	1.00
TM9E100C20MP11	FC/MC/PC48D	1.03	1.03	1.01
TM9E100C20MP11	UC48C	1.00	1.02	1.00
TM9E100C20MP11	UC48D	1.01	1.02	1.01
TM9E120D20MP11	FC/MC/PC48D	1.03	1.04	1.01
TM9E120D20MP11	UC48D	1.01	1.02	1.01
TM9X060B12MP11	FC/MC/PC35B	1.00	1.00	0.95
TM9X060B12MP11	FC/MC/PC43B	1.01	1.02	0.97
TM9X080B12MP11	FC/MC/PC35B	1.00	1.00	0.95
TM9X080B12MP11	FC/MC/PC43B	1.01	1.02	0.97
TM9X080C16MP11	FC/MC/PC35C	1.02	1.04	0.94
TM9X080C16MP11	FC/MC/PC43C	1.04	1.05	0.96
TM9X080C16MP11	FC/MC/PC48C	1.04	1.05	0.94
TM9X080C16MP11	FC/MC/PC48D	1.04	1.05	0.96
TM9X080C16MP11	UC48C	1.01	1.03	0.95
TM9X080C16MP11	UC48D	1.01	1.03	0.95
TM9X100C16MP11	FC/MC/PC35C	1.02	1.04	0.94
TM9X100C16MP11	FC/MC/PC43C	1.04	1.05	0.96
TM9X100C16MP11	FC/MC/PC48C	1.04	1.05	0.94
TM9X100C16MP11	FC/MC/PC48D	1.04	1.05	0.96
TM9X100C16MP11	UC48C	1.01	1.03	0.95
TM9X100C16MP11	UC48D	1.01	1.03	0.95
TM9X100C20MP11	FC/MC/PC35C	1.01	1.02	1.01
TM9X100C20MP11	FC/MC/PC43C	1.02	1.04	1.00
TM9X100C20MP11	FC/MC/PC48C	1.02	1.03	1.00
TM9X100C20MP11	FC/MC/PC48D	1.03	1.03	1.01
TM9X100C20MP11	UC48C	1.00	1.02	1.00
TM9X100C20MP11	UC48D	1.01	1.02	1.01
TM9X120D20MP11	FC/MC/PC48D	1.03	1.04	1.01
TM9X120D20MP11	UC48D	1.01	1.02	1.01
TMLX060A12MP11	FC/MC/PC32A	1.00	1.01	1.00
TMLX060A12MP11	FC/MC/PC37A	1.01	1.03	1.00
TMLX080B12MP11	FC/MC/PC35B	1.01	1.00	0.95
TMLX080B12MP11	FC/MC/PC43B	1.04	1.05	0.97
TMLX080C16MP11	FC/MC/PC35C	1.03	1.04	0.95
TMLX080C16MP11	FC/MC/PC43C	1.02	1.03	0.94
TMLX080C16MP11	FC/MC/PC48C	1.03	1.03	0.95
TMLX080C16MP11	FC/MC/PC48D	1.03	1.03	0.95
TMLX080C16MP11	UC48C	1.02	1.04	0.94
TMLX080C16MP11	UC48D	1.02	1.04	0.94
TMLX100C16MP11	FC/MC/PC35C	1.03	1.04	0.95
TMLX100C16MP11	FC/MC/PC43C	1.02	1.03	0.94
TMLX100C16MP11	FC/MC/PC48C	1.03	1.03	0.95
TMLX100C16MP11	FC/MC/PC48D	1.03	1.03	0.95
TMLX100C16MP11	UC48C	1.02	1.04	0.94

Furnaces	Coils	T.C.	S.C.	KW
TMLX100C16MP11	UC48D			
TMLX100C20MP11	FC/MC/PC35C	1.02	1.04	0.94
TMLX100C20MP11	FC/MC/PC43C	1.04	1.06	0.96
TMLX100C20MP11	FC/MC/PC48C	1.04	1.05	0.93
TMLX100C20MP11	FC/MC/PC48D	1.04	1.05	0.96
TMLX100C20MP11	UC48C	1.01	1.03	0.95
TMLX100C20MP11	UC48D	1.01	1.03	0.95
TMLX120C20MP11	FC/MC/PC35C	1.02	1.04	0.94
TMLX120C20MP11	FC/MC/PC43C	1.04	1.06	0.96
TMLX120C20MP11	FC/MC/PC48C	1.04	1.05	0.93
TMLX120C20MP11	FC/MC/PC48D	1.04	1.05	0.96
TMLX120C20MP11	UC48C	1.01	1.03	0.95
TMLX120C20MP11	UC48D	1.01	1.03	0.95
Y*(8,L)C*A12	FC/MC/PC32A	1.00	1.01	0.99
Y*(8,L)C*A12	FC/MC/PC37A	1.03	1.04	0.96
Y*(8,L)C*A12	HD36	1.00	0.97	0.95
Y*(8,L)C*B12	FC/MC/PC35B	1.01	1.02	0.95
Y*(8,L)C*B12	FC/MC/PC43B	1.03	1.05	0.94

Furnaces	Coils	T.C.	S.C.	KW
Y*(8,L)C*B12	HD36	1.00	0.98	0.92
Y*(8,L)C*C16	FC/MC/PC35C	1.01	1.03	0.93
Y*(8,L)C*C16	FC/MC/PC43C	1.04	1.05	0.91
Y*(8,L)C*C16	HD36	1.01	0.98	0.93
Y*(8,L)C*C20	FC/MC/PC35C	1.03	1.07	0.95
Y*(8,L)C*C20	FC/MC/PC43C	1.04	1.05	0.91
Y*(8,L)C*C20	HD36	1.01	1.01	0.92
Y*9C*B12	FC/MC/PC35B	1.01	1.04	0.97
Y*9C*B12	FC/MC/PC43B	1.03	1.04	0.96
Y*9C*B12	HD36	1.00	0.98	0.93
Y*9C*C16	FC/MC/PC35C	1.01	1.03	0.93
Y*9C*C16	FC/MC/PC43C	1.03	1.04	0.94
Y*9C*C16	HD36	1.01	0.98	0.93
Y*9C*C20	FC/MC/PC35C	1.01	1.03	0.93
Y*9C*C20	FC/MC/PC43C	1.04	1.05	0.92
Y*9C*C20	HD36	1.00	0.98	0.92

COOLING PERFORMANCE DATA																
AIR CONDITIONER MODEL NO.		TCHD36S41S3														
INDOOR COIL MODEL NO.		FC/MC/PC43														
AIR TEMP. ENTER- ING OUTDOOR UNIT (°F)	IDCFM	1000					1200					1400				
	ID DB (°F)	80	80	75	80	80	80	80	75	80	80	80	80	75	80	80
	ID WB (°F)	57	62	62	67	72	57	62	62	67	72	57	62	62	67	72
65	T.C.	35.6	35.8	34.7	37.7	37.7	36.8	37.8	36.7	40.3	42.2	38.1	39.7	38.6	42.8	46.7
	S.C.	32.9	30.2	25.1	25.3	17.8	34.5	33.0	28.0	27.7	20.2	36.2	35.7	30.8	30.1	22.7
	KW	1.90	1.92	1.90	1.92	1.95	1.91	1.93	1.90	1.92	1.95	1.92	1.94	1.90	1.92	1.95
75	T.C.	34.2	34.3	32.7	35.3	35.7	35.4	36.3	34.6	38.1	40.3	36.7	38.3	36.5	40.9	44.9
	S.C.	31.5	29.2	24.2	24.1	17.1	33.2	32.0	27.0	26.7	19.6	34.9	34.7	29.8	29.3	22.1
	KW	2.31	2.29	2.30	2.25	2.25	2.29	2.28	2.28	2.25	2.25	2.27	2.27	2.25	2.24	2.25
85	T.C.	32.8	32.8	30.7	33.0	33.7	34.0	34.8	32.5	36.0	38.4	35.3	36.8	34.4	38.9	43.2
	S.C.	30.0	28.2	23.3	22.9	16.5	31.8	31.0	26.0	25.7	19.0	33.6	33.8	28.7	28.4	21.6
	KW	2.72	2.67	2.69	2.57	2.55	2.68	2.64	2.65	2.57	2.55	2.63	2.61	2.61	2.56	2.55
95	T.C.	31.4	31.3	28.7	30.6	31.6	32.7	33.3	30.5	33.8	36.5	33.9	35.3	32.2	37.0	41.4
	S.C.	28.6	27.2	22.4	21.8	15.9	30.4	30.0	25.0	24.7	18.4	32.2	32.8	27.6	27.6	21.0
	KW	3.13	3.04	3.09	2.89	2.85	3.06	2.99	3.03	2.89	2.84	2.99	2.94	2.96	2.88	2.84
105	T.C.	29.9	29.4	27.2	29.0	29.7	31.0	31.1	28.7	31.9	34.3	32.2	32.9	30.2	34.9	38.8
	S.C.	27.3	26.5	21.9	21.2	15.2	28.9	28.8	24.4	24.0	17.7	30.5	31.1	26.9	26.9	20.1
	KW	3.67	3.60	3.71	3.42	3.34	3.58	3.52	3.61	3.41	3.33	3.50	3.44	3.51	3.40	3.32
115	T.C.	28.4	27.6	25.6	27.3	27.8	29.4	29.0	26.9	30.1	32.1	30.5	30.5	28.3	32.9	36.3
	S.C.	25.9	25.9	21.4	20.6	14.6	27.4	27.7	23.8	23.4	16.9	28.9	29.5	26.2	26.1	19.2
	KW	4.20	4.13	4.32	3.94	3.81	4.09	4.03	4.18	3.91	3.79	3.99	3.93	4.05	3.89	3.78
125	T.C.	26.9	25.7	24.1	25.7	25.9	27.8	27.0	25.2	28.3	29.8	28.8	28.2	26.3	30.9	33.8
	S.C.	24.6	25.3	20.9	20.0	14.0	26.0	26.6	23.2	22.7	16.2	27.3	27.8	25.6	25.4	18.3
	KW	4.72	4.67	4.92	4.45	4.28	4.60	4.54	4.75	4.42	4.26	4.49	4.41	4.58	4.39	4.24

NOTE: ALL CAPACITIES INCLUDE INDOOR FAN HEAT. KW VALUES ARE FOR THE SYSTEM (OUTDOOR + INDOOR).

Blue shaded cells are AHRI conditions. Green shaded cells are ACCA (TVA) conditions.

Multipliers for determining the performance with other indoor sections.

NOTE: For dry bulb temperatures different than those listed (between 73-87 °F), sensible capacity increases by 1060 BTUH per 1000 CFM per degree above the listed temperature and decreases by 1060 BTUH per 1000 CFM per degree below the listed temperature.

Air Handlers	Coils	T.C.	S.C.	KW
–	FC/MC/PC37	1.00	1.00	1.00
–	FC/MC/PC43	1.00	1.00	1.00
–	FC/MC/PC48	1.02	1.02	0.99
–	HD48	1.01	1.01	1.00
AHE36C	–	1.02	1.03	0.93
AHE42D	–	1.04	1.04	0.91
AHR36B	–	1.00	1.00	1.02
AHR42C	–	1.02	1.04	1.00
AHV36C	–	1.02	1.04	0.99
AHV42D	–	1.04	1.04	0.95
AHV48D	–	1.02	1.02	0.95
MV12B	FC/MC43B	1.02	1.02	0.95

Air Handlers	Coils	T.C.	S.C.	KW
MV12D	FC/MC48D	1.02	1.02	0.92
MV16C	FC/MC43C	1.02	1.03	0.92
MV16C	FC/MC48C	1.04	1.04	0.92
MX12BN21	FC/MC35B	0.99	0.98	0.98
MX12BN21	FC/MC43B	1.00	0.99	0.95
MX12DN21	FC/MC48D	1.01	1.02	0.91
MX16CN21	FC/MC35C	0.99	1.00	0.99
MX16CN21	FC/MC43C	1.01	1.02	0.95
MX16CN21	FC/MC48C	1.02	1.04	0.95
MX20DN21	FC/MC48D	1.03	1.05	0.94

Furnaces	Coils	T.C.	S.C.	KW
T*(8,L)C*A12	FC/MC/PC32A	0.96	0.96	0.96
T*(8,L)C*A12	FC/MC/PC37A	0.98	0.93	0.95
T*(8,L)C*A12	HD36	0.98	0.94	0.98
T*(8,L)C*B12	FC/MC/PC35B	0.99	0.95	0.98
T*(8,L)C*B12	FC/MC/PC43B	1.01	1.02	0.99
T*(8,L)C*B12	HD36	0.98	0.94	0.96
T*(8,L)C*B12	HD48	1.02	1.02	0.96
T*(8,L)C*C16	FC/MC/PC35C	0.99	0.96	0.95
T*(8,L)C*C16	FC/MC/PC43C	1.02	1.03	0.95
T*(8,L)C*C16	FC/MC/PC48C	1.04	1.05	0.93
T*(8,L)C*C16	HD36	0.99	0.95	0.94
T*(8,L)C*C16	HD48	1.03	1.03	0.93
T*(8,L)C*C16	UC48C	0.99	1.00	0.93
T*(8,L)C*C20	FC/MC/PC35C	1.00	0.96	0.93
T*(8,L)C*C20	FC/MC/PC43C	1.02	1.03	0.96
T*(8,L)C*C20	FC/MC/PC48C	1.04	1.05	0.93
T*(8,L)C*C20	HD36	0.99	0.96	0.94
T*(8,L)C*C20	HD48	1.03	1.03	0.92
T*(8,L)C*C20	UC48C	0.99	1.00	0.92
T*(8,L)V*A12	FC/MC/PC37A	0.98	0.93	0.95
T*(8,L)V*B12	FC/MC/PC43B	1.01	1.02	0.99
T*(8,L)V*B12	HD48	1.02	1.02	0.96
T*(8,L)V*C16	FC/MC/PC43C	1.02	1.03	0.95
T*(8,L)V*C16	FC/MC/PC48C	1.04	1.05	0.93
T*(8,L)V*C16	HD48	1.03	1.03	0.93
T*(8,L)V*C16	UC48C	0.99	1.00	0.93
T*(8,L)V*C20	FC/MC/PC43C	1.02	1.03	0.96
T*(8,L)V*C20	FC/MC/PC48C	1.04	1.05	0.93
T*(8,L)V*C20	HD48	1.03	1.03	0.92
T*(8,L)V*C20	UC48C	0.99	1.00	0.92
T*9(C,V)*B12	FC/MC/PC35B	0.99	1.00	0.98
T*9(C,V)*B12	FC/MC/PC43B	1.01	1.02	0.98
T*9(C,V)*B12	HD36	0.99	1.00	0.96
T*9(C,V)*B12	HD48	1.02	1.02	0.96
T*9(C,V)*C16	FC/MC/PC35C	0.99	1.00	0.96
T*9(C,V)*C16	FC/MC/PC43C	1.01	1.02	0.97
T*9(C,V)*C16	FC/MC/PC48C	1.04	1.04	0.95
T*9(C,V)*C16	HD36	0.99	1.00	0.94
T*9(C,V)*C16	HD48	1.02	1.02	0.94
T*9(C,V)*C16	UC48C	0.99	1.00	0.94
T*9(C,V)*C20	FC/MC/PC35C	1.01	1.04	0.99
T*9(C,V)*C20	FC/MC/PC43C	1.02	1.03	0.95
T*9(C,V)*C20	FC/MC/PC48C	1.04	1.09	0.97
T*9(C,V)*C20	HD36	1.00	1.01	0.97
T*9(C,V)*C20	HD48	1.03	1.06	0.97
T*9(C,V)*C20	UC48C	1.00	1.03	0.98
T*9(C,V)*D20	FC/MC/PC48D	1.04	1.06	0.94
T*9(C,V)*D20	HD48	1.03	1.04	0.94
T*9(C,V)*D20	UC48D	0.99	1.00	0.94
TM8X060A12MP11	FC/MC/PC37A	0.99	0.98	0.98
TM8X080B12MP11	FC/MC/PC35B	0.98	0.97	1.00
TM8X080B12MP11	FC/MC/PC43B	0.99	0.98	0.97
TM8X080C16MP11	FC/MC/PC35C	0.99	0.98	0.97
TM8X080C16MP11	FC/MC/PC43C	1.00	0.99	0.94
TM8X080C16MP11	FC/MC/PC48C	1.01	1.01	0.93
TM8X080C16MP11	FC/MC/PC48D	1.01	1.01	0.96
TM8X080C16MP11	UC48C	1.00	1.01	0.98
TM8X080C16MP11	UC48D	1.00	1.01	0.96
TM8X100C16MP11	FC/MC/PC35C	0.99	0.98	0.97
TM8X100C16MP11	FC/MC/PC43C	1.00	0.99	0.94
TM8X100C16MP11	FC/MC/PC48C	1.01	1.01	0.93
TM8X100C16MP11	FC/MC/PC48D	1.01	1.01	0.96

Furnaces	Coils	T.C.	S.C.	KW
TM8X100C16MP11	UC48C	1.00	1.01	0.98
TM8X100C16MP11	UC48D	1.00	1.01	0.96
TM8X100C20MP11	FC/MC/PC35C	0.99	1.01	0.97
TM8X100C20MP11	FC/MC/PC43C	1.02	1.02	0.95
TM8X100C20MP11	FC/MC/PC48C	1.02	1.04	0.95
TM8X100C20MP11	FC/MC/PC48D	1.02	1.04	0.98
TM8X100C20MP11	UC48C	0.99	1.01	0.97
TM8X100C20MP11	UC48D	0.99	1.01	0.97
TM8X120C20MP11	FC/MC/PC35C	0.99	1.01	0.97
TM8X120C20MP11	FC/MC/PC43C	1.02	1.02	0.95
TM8X120C20MP11	FC/MC/PC48C	1.02	1.04	0.95
TM8X120C20MP11	FC/MC/PC48D	1.02	1.04	0.98
TM8X120C20MP11	UC48C	0.99	1.01	0.97
TM8X120C20MP11	UC48D	0.99	1.01	0.97
TM9E060B12MP11	FC/MC/PC35B	0.98	0.97	1.00
TM9E060B12MP11	FC/MC/PC43B	0.99	0.98	0.97
TM9E080B12MP11	FC/MC/PC35B	0.98	0.97	1.00
TM9E080B12MP11	FC/MC/PC43B	0.99	0.98	0.97
TM9E080C16MP11	FC/MC/PC35C	0.99	0.98	0.98
TM9E080C16MP11	FC/MC/PC43C	1.00	0.99	0.96
TM9E080C16MP11	FC/MC/PC48C	1.01	1.00	0.95
TM9E080C16MP11	FC/MC/PC48D	1.01	1.00	0.98
TM9E080C16MP11	UC48C	0.99	1.01	0.97
TM9E080C16MP11	UC48D	0.99	1.01	0.97
TM9E100C16MP11	FC/MC/PC35C	0.99	0.98	0.98
TM9E100C16MP11	FC/MC/PC43C	1.00	0.99	0.96
TM9E100C16MP11	FC/MC/PC48C	1.01	1.00	0.95
TM9E100C16MP11	FC/MC/PC48D	1.01	1.00	0.98
TM9E100C16MP11	UC48C	0.99	1.01	0.97
TM9E100C16MP11	UC48D	0.99	1.01	0.97
TM9E100C20MP11	FC/MC/PC35C	0.99	0.98	0.96
TM9E100C20MP11	FC/MC/PC43C	1.00	0.99	0.96
TM9E100C20MP11	FC/MC/PC48C	1.01	1.00	0.95
TM9E100C20MP11	FC/MC/PC48D	1.01	1.01	0.96
TM9E100C20MP11	UC48C	0.99	1.01	0.97
TM9E100C20MP11	UC48D	0.99	1.01	0.97
TM9E120D20MP11	FC/MC/PC48D	1.01	1.01	0.94
TM9E120D20MP11	UC48D	1.00	1.01	0.98
TM9X060B12MP11	FC/MC/PC35B	0.98	0.97	1.00
TM9X060B12MP11	FC/MC/PC43B	0.99	0.98	0.97
TM9X080B12MP11	FC/MC/PC35B	0.98	0.97	1.00
TM9X080B12MP11	FC/MC/PC43B	0.99	0.98	0.97
TM9X080C16MP11	FC/MC/PC35C	0.99	0.98	0.98
TM9X080C16MP11	FC/MC/PC43C	1.00	0.99	0.96
TM9X080C16MP11	FC/MC/PC48C	1.01	1.00	0.95
TM9X080C16MP11	FC/MC/PC48D	1.01	1.00	0.98
TM9X080C16MP11	UC48C	0.99	1.01	0.97
TM9X080C16MP11	UC48D	0.99	1.01	0.97
TM9X100C16MP11	FC/MC/PC35C	0.99	0.98	0.98
TM9X100C16MP11	FC/MC/PC43C	1.00	0.99	0.96
TM9X100C16MP11	FC/MC/PC48C	1.01	1.00	0.95
TM9X100C16MP11	FC/MC/PC48D	1.01	1.00	0.98
TM9X100C16MP11	UC48C	0.99	1.01	0.97
TM9X100C16MP11	UC48D	0.99	1.01	0.97
TM9X100C20MP11	FC/MC/PC35C	0.99	0.98	0.96
TM9X100C20MP11	FC/MC/PC43C	1.00	0.99	0.96
TM9X100C20MP11	FC/MC/PC48C	1.01	1.00	0.95
TM9X100C20MP11	FC/MC/PC48D	1.01	1.01	0.96
TM9X100C20MP11	UC48C	0.99	1.01	0.97
TM9X100C20MP11	UC48D	0.99	1.01	0.97
TM9X120D20MP11	FC/MC/PC48D	1.01	1.01	0.94
TM9X120D20MP11	UC48D	1.00	1.01	0.98

Furnaces	Coils	T.C.	S.C.	KW
TMLX060A12MP11	FC/MC/PC37A	0.99	0.98	0.98
TMLX080B12MP11	FC/MC/PC35B	0.98	0.97	1.00
TMLX080B12MP11	FC/MC/PC43B	0.99	0.98	0.97
TMLX080C16MP11	FC/MC/PC35C	0.99	0.98	0.97
TMLX080C16MP11	FC/MC/PC43C	1.00	0.99	0.94
TMLX080C16MP11	FC/MC/PC48C	1.01	1.01	0.93
TMLX080C16MP11	FC/MC/PC48D	1.01	1.01	0.96
TMLX080C16MP11	UC48C	1.00	1.01	0.98
TMLX080C16MP11	UC48D	1.00	1.01	0.96
TMLX100C16MP11	FC/MC/PC35C	0.99	0.98	0.97
TMLX100C16MP11	FC/MC/PC43C	1.00	0.99	0.94
TMLX100C16MP11	FC/MC/PC48C	1.01	1.01	0.93
TMLX100C16MP11	FC/MC/PC48D	1.01	1.01	0.96
TMLX100C16MP11	UC48C	1.00	1.01	0.98
TMLX100C16MP11	UC48D	1.00	1.01	0.96
TMLX100C20MP11	FC/MC/PC35C	0.99	1.01	0.97
TMLX100C20MP11	FC/MC/PC43C	1.02	1.02	0.95
TMLX100C20MP11	FC/MC/PC48C	1.02	1.04	0.95
TMLX100C20MP11	FC/MC/PC48D	1.02	1.04	0.98
TMLX100C20MP11	UC48C	0.99	1.01	0.97
TMLX100C20MP11	UC48D	0.99	1.01	0.97
TMLX120C20MP11	FC/MC/PC35C	0.99	1.01	0.97
TMLX120C20MP11	FC/MC/PC43C	1.02	1.02	0.95
TMLX120C20MP11	FC/MC/PC48C	1.02	1.04	0.95
TMLX120C20MP11	FC/MC/PC48D	1.02	1.04	0.98
TMLX120C20MP11	UC48C	0.99	1.01	0.97

Furnaces	Coils	T.C.	S.C.	KW
TMLX120C20MP11	UC48D	0.99	1.01	0.97
Y*(8,L)C*A12	FC/MC/PC37A	0.98	0.93	0.95
Y*(8,L)C*B12	FC/MC/PC43B	1.01	1.02	0.99
Y*(8,L)C*B12	HD48	1.02	1.02	0.96
Y*(8,L)C*C16	FC/MC/PC43C	1.02	1.03	0.95
Y*(8,L)C*C16	FC/MC/PC48C	1.04	1.05	0.93
Y*(8,L)C*C16	HD48	1.03	1.03	0.93
Y*(8,L)C*C16	UC48C	0.99	1.00	0.93
Y*(8,L)C*C20	FC/MC/PC43C	1.02	1.03	0.96
Y*(8,L)C*C20	FC/MC/PC48C	1.04	1.05	0.93
Y*(8,L)C*C20	HD48	1.03	1.03	0.92
Y*(8,L)C*C20	UC48C	0.99	1.00	0.92
Y*9C*B12	FC/MC/PC43B	1.01	1.02	0.98
Y*9C*B12	HD48	1.02	1.02	0.96
Y*9C*C16	FC/MC/PC43C	1.01	1.02	0.97
Y*9C*C16	FC/MC/PC48C	1.04	1.04	0.95
Y*9C*C16	HD48	1.02	1.02	0.94
Y*9C*C16	UC48C	0.99	1.00	0.94
Y*9C*C20	FC/MC/PC43C	1.02	1.03	0.95
Y*9C*C20	FC/MC/PC48C	1.04	1.09	0.97
Y*9C*C20	HD48	1.03	1.06	0.97
Y*9C*C20	UC48C	1.00	1.03	0.98
Y*9C*D20	FC/MC/PC48D	1.04	1.06	0.94
Y*9C*D20	HD48	1.03	1.04	0.94
Y*9C*D20	UC48D	0.99	1.00	0.94

COOLING PERFORMANCE DATA																
AIR CONDITIONER MODEL NO.		TCHD48S41S3														
INDOOR COIL MODEL NO.		FC/MC/PC48														
AIR TEMP. ENTER- ING OUTDOOR UNIT (°F)	IDCFM	1400					1600					1800				
	ID DB (°F)	80	80	75	80	80	80	80	75	80	80	80	80	75	80	80
	ID WB (°F)	57	62	62	67	72	57	62	62	67	72	57	62	62	67	72
65	T.C.	44.8	47.3	47.9	52.2	56.8	46.3	48.2	48.8	53.2	58.1	47.8	49.1	49.7	54.3	59.4
	S.C.	44.8	40.3	34.7	34.4	26.8	46.3	42.9	36.8	36.7	28.0	47.8	45.5	38.9	39.0	29.2
	KW	2.74	2.71	2.74	2.72	2.73	2.73	2.72	2.74	2.72	2.74	2.73	2.72	2.74	2.72	2.75
75	T.C.	43.4	45.6	46.0	50.2	54.7	44.8	46.5	46.8	51.2	55.9	46.2	47.4	47.7	52.1	57.2
	S.C.	43.4	40.1	34.1	33.6	26.0	44.8	42.7	36.3	35.7	27.1	46.2	45.3	38.5	37.9	28.3
	KW	3.21	3.19	3.21	3.18	3.17	3.20	3.19	3.20	3.17	3.18	3.18	3.18	3.19	3.17	3.18
85	T.C.	42.0	44.0	44.1	48.2	52.5	43.3	44.9	44.9	49.1	53.7	44.6	45.8	45.7	49.9	54.9
	S.C.	42.0	40.0	33.6	32.8	25.2	43.3	42.5	35.9	34.8	26.3	44.6	45.1	38.2	36.8	27.4
	KW	3.69	3.68	3.68	3.64	3.61	3.66	3.65	3.66	3.63	3.61	3.63	3.63	3.64	3.62	3.61
95	T.C.	40.5	42.4	42.2	46.2	50.3	41.8	43.3	42.9	47.0	51.5	43.0	44.1	43.6	47.8	52.7
	S.C.	40.5	39.8	33.1	32.0	24.4	41.8	42.4	35.5	33.8	25.5	43.0	44.1	37.9	35.7	26.6
	KW	4.17	4.16	4.15	4.10	4.05	4.13	4.12	4.12	4.09	4.05	4.08	4.09	4.09	4.07	4.04
105	T.C.	37.9	38.7	37.3	43.4	47.6	39.2	40.2	38.6	44.1	48.7	40.5	41.6	39.9	44.9	49.8
	S.C.	37.9	37.2	31.1	30.8	23.4	39.2	39.7	33.6	32.8	24.6	40.5	41.6	36.1	34.7	25.7
	KW	5.42	5.57	5.70	4.94	4.79	5.16	5.24	5.52	4.90	4.78	4.90	4.91	5.34	4.86	4.77
115	T.C.	35.4	35.2	32.6	40.6	44.9	36.7	37.2	34.4	41.3	45.9	38.1	39.1	36.3	42.1	46.9
	S.C.	35.4	34.6	29.2	29.7	22.6	36.7	37.2	31.8	31.7	23.8	38.1	39.1	34.4	33.6	24.9
	KW	6.63	6.93	7.21	5.75	5.50	6.16	6.32	6.88	5.69	5.49	5.69	5.71	6.55	5.62	5.48
125	T.C.	32.9	31.7	27.8	37.8	42.3	34.2	34.2	30.2	38.6	43.2	35.6	36.7	32.7	39.3	44.1
	S.C.	32.9	31.7	27.3	28.7	21.7	34.2	34.2	30.0	30.6	22.9	35.6	36.7	32.7	32.6	24.1
	KW	7.84	8.30	8.72	6.57	6.21	7.16	7.40	8.24	6.47	6.20	6.48	6.50	7.76	6.38	6.20

NOTE: ALL CAPACITIES INCLUDE INDOOR FAN HEAT. KW VALUES ARE FOR THE SYSTEM (OUTDOOR + INDOOR).

Blue shaded cells are AHRI conditions. Green shaded cells are ACCA (TVA) conditions.

Multipliers for determining the performance with other indoor sections.

NOTE: For dry bulb temperatures different than those listed (between 73-87 °F), sensible capacity increases by 1060 BTUH per 1000 CFM per degree above the listed temperature and decreases by 1060 BTUH per 1000 CFM per degree below the listed temperature.

Air Handlers	Coils	T.C.	S.C.	KW
-	FC/MC/PC48	1.00	1.00	1.00
-	FC/MC/PC60	0.99	0.98	1.01
-	FC/MC62	1.01	1.01	1.00
-	FC64	1.03	1.05	1.01
AHE48D	-	1.00	1.01	0.96
AHE60D	-	1.02	1.02	0.96
AHR48D	-	1.00	1.01	1.00
AHR60D	-	1.01	1.02	1.01
AHV48D	-	0.99	0.98	0.99
AHV60D	-	1.00	1.01	0.98
MV16C	FC/MC48C	1.01	1.01	0.96
MV16C	FC60C	1.00	0.99	0.98
MV20D	FC/MC48D	1.01	1.01	0.97
MV20D	FC/MC60D	0.97	0.98	0.96
MV20D	FC/MC62D	1.02	1.02	0.96
MV20D	FC64D	1.05	1.07	0.97
MX16CN21	FC/MC48C	0.99	0.99	0.96
MX16CN21	FC60C	0.99	0.99	0.95
MX20DN21	FC/MC48D	0.99	0.98	0.93
MX20DN21	FC/MC60D	1.00	0.99	0.94
MX20DN21	FC/MC62D	1.00	1.00	0.92
MX20DN21	FC64D	1.03	1.03	0.93

Furnaces	Coils	T.C.	S.C.	KW
T*(8,L)C*C16	FC/MC/PC48C	1.00	1.01	1.00
T*(8,L)C*C16	FC/PC60C	0.99	1.00	0.99
T*(8,L)C*C16	FC64D	1.04	1.06	0.98
T*(8,L)C*C16	HD48	1.00	1.01	0.99

Furnaces	Coils	T.C.	S.C.	KW
T*(8,L)C*C16	HD60	1.01	1.02	0.98
T*(8,L)C*C16	UC48C	0.97	0.98	0.98
T*(8,L)C*C16	UC60C	0.98	0.97	0.98
T*(8,L)C*C20	FC/MC/PC48C	1.00	1.01	0.99
T*(8,L)C*C20	FC/PC60C	1.00	1.01	0.99
T*(8,L)C*C20	FC64D	1.04	1.06	0.98
T*(8,L)C*C20	HD48	1.00	1.01	0.99
T*(8,L)C*C20	HD60	1.01	1.02	0.96
T*(8,L)C*C20	UC48C	0.97	0.98	0.98
T*(8,L)C*C20	UC60C	0.98	0.98	0.96
T*(8,L)V*C16	FC/MC/PC48C	1.00	1.01	1.00
T*(8,L)V*C16	FC/PC60C	0.99	1.00	0.99
T*(8,L)V*C16	FC64D	1.04	1.06	0.98
T*(8,L)V*C16	HD60	1.01	1.02	0.98
T*(8,L)V*C16	UC48C	0.97	0.98	0.98
T*(8,L)V*C16	UC60C	0.98	0.97	0.98
T*(8,L)V*C20	FC/MC/PC48C	1.00	1.01	0.99
T*(8,L)V*C20	FC/PC60C	1.00	1.01	0.99
T*(8,L)V*C20	FC64D	1.04	1.06	0.98
T*(8,L)V*C20	HD60	1.01	1.02	0.96
T*(8,L)V*C20	UC48C	0.97	0.98	0.98
T*(8,L)V*C20	UC60C	0.98	0.98	0.96
T*9(C,V)*C16	FC/MC/PC48C	1.00	1.00	0.99
T*9(C,V)*C16	FC/PC60C	1.00	1.02	0.99
T*9(C,V)*C16	FC64D	1.04	1.05	1.00
T*9(C,V)*C16	HD48	1.00	1.01	0.99
T*9(C,V)*C16	HD60	1.00	1.01	0.99
T*9(C,V)*C16	UC48C	0.97	0.98	0.99

Furnaces	Coils	T.C.	S.C.	KW	Furnaces	Coils	T.C.	S.C.	KW
T*9(C,V)*C16	UC60C	0.97	0.97	0.99	TMLX080C16MP11	FC/MC/PC60D	0.99	0.98	1.01
T*9(C,V)*C20	FC/MC/PC48C	1.01	1.02	0.99	TMLX080C16MP11	FC/MC62D	0.99	0.99	0.99
T*9(C,V)*C20	FC/PC60C	1.00	1.02	0.99	TMLX080C16MP11	FC/PC60C	0.99	0.98	0.99
T*9(C,V)*C20	FC64D	1.04	1.05	1.02	TMLX080C16MP11	FC64D	1.02	1.01	0.97
T*9(C,V)*C20	HD48	1.00	1.01	0.99	TMLX100C16MP11	FC/MC/PC48C	0.98	0.96	0.98
T*9(C,V)*C20	HD60	1.00	1.01	0.99	TMLX100C16MP11	FC/MC/PC60D	0.99	0.98	1.01
T*9(C,V)*C20	UC48C	0.97	0.98	0.99	TMLX100C16MP11	FC/MC62D	0.99	0.99	0.99
T*9(C,V)*C20	UC60C	0.97	0.97	0.99	TMLX100C16MP11	FC/PC60C	0.99	0.98	0.99
T*9(C,V)*D20	FC/MC/PC48D	1.01	1.02	0.99	TMLX100C16MP11	FC64D	1.02	1.01	0.97
T*9(C,V)*D20	FC/MC/PC60D	1.00	1.02	0.98	TMLX100C20MP11	FC/MC/PC48C	0.98	0.97	0.96
T*9(C,V)*D20	FC/MC62D	1.01	1.02	0.98	TMLX100C20MP11	FC/MC/PC60D	0.99	0.98	0.99
T*9(C,V)*D20	FC64D	1.04	1.05	1.00	TMLX100C20MP11	FC/MC62D	0.99	0.99	0.97
T*9(C,V)*D20	HD48	1.00	1.01	0.99	TMLX100C20MP11	FC/PC60C	0.99	0.98	0.99
T*9(C,V)*D20	HD60	1.01	1.02	0.99	TMLX100C20MP11	FC64D	1.02	1.01	0.96
T*9(C,V)*D20	UC48D	0.97	0.98	0.99	TMLX100C20MP11	UC60C	0.98	0.95	0.97
T*9(C,V)*D20	UC60D	0.98	0.97	0.99	TMLX100C20MP11	UC60D	0.98	0.95	0.96
TM8X080C16MP11	FC/MC/PC48C	0.98	0.96	0.98	TMLX100C20MP11	UC60D	0.98	0.95	0.96
TM8X080C16MP11	FC/MC/PC60D	0.99	0.98	1.01	TMLX120C20MP11	FC/MC/PC48C	0.98	0.97	0.96
TM8X080C16MP11	FC/MC62D	0.99	0.99	0.99	TMLX120C20MP11	FC/MC/PC48D	0.98	0.97	0.98
TM8X080C16MP11	FC/PC60C	0.99	0.98	0.99	TMLX120C20MP11	FC/MC/PC60D	0.99	0.98	0.99
TM8X080C16MP11	FC64D	1.02	1.01	0.97	TMLX120C20MP11	FC/MC62D	0.99	0.99	0.97
TM8X100C16MP11	FC/MC/PC48C	0.98	0.96	0.98	TMLX120C20MP11	FC/PC60C	0.99	0.98	0.99
TM8X100C16MP11	FC/MC/PC60D	0.99	0.98	1.01	TMLX120C20MP11	FC64D	1.02	1.01	0.96
TM8X100C16MP11	FC/MC62D	0.99	0.99	0.99	TMLX120C20MP11	UC60C	0.98	0.95	0.97
TM8X100C16MP11	FC/PC60C	0.99	0.98	0.99	TMLX120C20MP11	UC60D	0.98	0.95	0.96
TM8X100C16MP11	FC64D	1.02	1.01	0.97	Y*(8,L)C*C16	FC/MC/PC48C	1.00	1.01	1.00
TM8X100C20MP11	FC/MC/PC48C	0.98	0.97	0.96	Y*(8,L)C*C16	FC/PC60C	0.99	1.00	0.99
TM8X100C20MP11	FC/MC/PC48D	0.98	0.97	0.98	Y*(8,L)C*C16	FC64D	1.04	1.06	0.98
TM8X100C20MP11	FC/MC/PC60D	0.99	0.98	0.99	Y*(8,L)C*C16	HD60	1.01	1.02	0.98
TM8X100C20MP11	FC/MC62D	0.99	0.99	0.97	Y*(8,L)C*C16	UC48C	0.97	0.98	0.98
TM8X100C20MP11	FC/PC60C	0.99	0.98	0.99	Y*(8,L)C*C16	UC60C	0.98	0.97	0.98
TM8X100C20MP11	FC64D	1.02	1.01	0.96	Y*(8,L)C*C20	FC/MC/PC48C	1.00	1.01	0.99
TM8X100C20MP11	UC60C	0.98	0.95	0.97	Y*(8,L)C*C20	FC/PC60C	1.00	1.01	0.99
TM8X100C20MP11	UC60D	0.98	0.95	0.96	Y*(8,L)C*C20	FC64D	1.04	1.06	0.98
TM8X120C20MP11	FC/MC/PC48C	0.98	0.97	0.96	Y*(8,L)C*C20	HD60	1.01	1.02	0.96
TM8X120C20MP11	FC/MC/PC48D	0.98	0.97	0.98	Y*(8,L)C*C20	UC48C	0.97	0.98	0.98
TM8X120C20MP11	FC/MC/PC60D	0.99	0.98	0.99	Y*(8,L)C*C20	UC60C	0.98	0.98	0.96
TM8X120C20MP11	FC/MC62D	0.99	0.99	0.97	Y*9C*C16	FC/MC/PC48C	1.00	1.00	0.99
TM8X120C20MP11	FC/PC60C	0.99	0.98	0.99	Y*9C*C16	FC/PC60C	1.00	1.02	0.99
TM8X120C20MP11	FC64D	1.02	1.01	0.96	Y*9C*C16	FC64D	1.04	1.05	1.00
TM8X120C20MP11	UC60C	0.98	0.95	0.97	Y*9C*C16	HD60	1.00	1.01	0.99
TM8X120C20MP11	UC60D	0.98	0.95	0.96	Y*9C*C16	UC48C	0.97	0.98	0.99
TM9E100C20MP11	FC/MC62D	0.99	0.99	0.99	Y*9C*C16	UC60C	0.97	0.97	0.99
TM9E100C20MP11	FC64D	1.02	1.01	0.97	Y*9C*C20	FC/MC/PC48C	1.01	1.02	0.99
TM9E120D20MP11	FC/MC/PC48D	0.98	0.96	0.98	Y*9C*C20	FC/PC60C	1.00	1.02	0.99
TM9E120D20MP11	FC/MC/PC60D	0.99	0.98	0.97	Y*9C*C20	FC64D	1.04	1.05	1.02
TM9E120D20MP11	FC/MC62D	0.99	0.99	0.99	Y*9C*C20	HD60	1.00	1.01	0.99
TM9E120D20MP11	FC64D	1.02	1.01	0.97	Y*9C*C20	UC48C	0.97	0.98	0.99
TM9E120D20MP11	UC60D	0.98	0.95	0.98	Y*9C*C20	UC60C	0.97	0.97	0.99
TM9X100C20MP11	FC/MC62D	0.99	0.99	0.99	Y*9C*D20	FC/MC/PC48D	1.01	1.02	0.99
TM9X100C20MP11	FC64D	1.02	1.01	0.97	Y*9C*D20	FC/MC/PC60D	1.00	1.02	0.98
TM9X120D20MP11	FC/MC/PC48D	0.98	0.96	0.98	Y*9C*D20	FC/MC62D	1.01	1.02	0.98
TM9X120D20MP11	FC/MC/PC60D	0.99	0.98	0.97	Y*9C*D20	FC64D	1.04	1.05	1.00
TM9X120D20MP11	FC/MC62D	0.99	0.99	0.99	Y*9C*D20	HD60	1.01	1.02	0.99
TM9X120D20MP11	FC64D	1.02	1.01	0.97	Y*9C*D20	UC48D	0.97	0.98	0.99
TM9X120D20MP11	UC60D	0.98	0.95	0.98	Y*9C*D20	UC60D	0.98	0.97	0.99
TMLX080C16MP11	FC/MC/PC48C	0.98	0.96	0.98					

COOLING PERFORMANCE DATA																
AIR CONDITIONER MODEL NO.		TCHD60S41S3														
INDOOR COIL MODEL NO.		FC/MC62														
AIR TEMP. ENTER- ING OUTDOOR UNIT (°F)	IDCFM	1600					1800					2000				
	ID DB (°F)	80	80	75	80	80	80	80	75	80	80	80	80	75	80	80
	ID WB (°F)	57	62	62	67	72	57	62	62	67	72	57	62	62	67	72
65	T.C.	54.0	58.2	58.3	62.9	68.5	55.4	59.4	59.3	64.2	69.8	56.9	60.6	60.3	65.4	71.0
	S.C.	54.0	49.2	41.5	41.2	31.7	55.4	51.9	43.5	43.0	32.8	56.9	54.5	45.5	44.8	34.0
	KW	3.32	3.35	3.32	3.40	3.48	3.34	3.37	3.34	3.43	3.50	3.37	3.39	3.36	3.45	3.52
75	T.C.	51.8	55.7	55.7	60.6	66.1	53.3	56.9	56.7	61.8	67.3	54.8	58.0	57.8	63.0	68.5
	S.C.	51.8	47.8	40.2	39.9	30.8	53.3	50.4	42.2	41.8	31.9	54.8	53.1	44.2	43.7	33.1
	KW	3.96	3.98	3.98	4.00	4.05	3.97	3.99	3.98	4.01	4.06	3.98	3.99	3.99	4.03	4.08
85	T.C.	49.7	53.3	53.2	58.3	63.8	51.2	54.3	54.2	59.4	64.9	52.8	55.4	55.2	60.5	66.0
	S.C.	49.7	46.4	38.9	38.6	29.8	51.2	49.0	40.9	40.6	31.0	52.8	51.7	42.9	42.5	32.1
	KW	4.61	4.61	4.63	4.59	4.61	4.59	4.60	4.62	4.60	4.62	4.58	4.60	4.61	4.60	4.63
95	T.C.	47.6	50.8	50.6	55.9	61.4	49.2	51.8	51.6	57.0	62.4	50.7	52.8	52.6	58.1	63.4
	S.C.	47.6	45.0	37.6	37.4	28.9	49.2	47.6	39.6	39.3	30.1	50.7	50.2	41.5	41.3	31.2
	KW	5.25	5.23	5.29	5.19	5.18	5.22	5.22	5.26	5.18	5.18	5.18	5.20	5.24	5.17	5.19
105	T.C.	44.8	47.6	47.4	52.8	58.3	46.3	48.6	48.3	53.8	59.3	47.8	49.7	49.2	54.9	60.3
	S.C.	44.8	43.1	36.1	36.0	27.8	46.3	45.7	38.0	38.0	29.0	47.8	48.2	39.9	39.9	30.1
	KW	6.46	6.36	6.48	6.18	6.04	6.35	6.31	6.42	6.15	6.01	6.25	6.25	6.36	6.11	5.98
115	T.C.	42.0	44.4	44.3	49.8	55.2	43.5	45.6	45.2	50.8	56.3	45.0	46.7	46.0	51.7	57.4
	S.C.	42.0	41.3	34.6	34.7	26.8	43.5	43.8	36.5	36.6	27.9	45.0	46.3	38.4	38.6	29.1
	KW	7.64	7.46	7.63	7.14	6.88	7.46	7.36	7.54	7.08	6.81	7.28	7.27	7.45	7.03	6.75
125	T.C.	39.3	41.3	41.2	46.8	52.1	40.7	42.5	42.0	47.7	53.2	42.1	43.7	42.8	48.6	54.4
	S.C.	39.3	39.5	33.2	33.4	25.7	40.7	41.9	35.0	35.3	26.9	42.1	43.7	36.9	37.2	28.1
	KW	8.81	8.56	8.78	8.10	7.72	8.56	8.42	8.66	8.02	7.62	8.31	8.29	8.54	7.94	7.52

NOTE: ALL CAPACITIES INCLUDE INDOOR FAN HEAT. KW VALUES ARE FOR THE SYSTEM (OUTDOOR + INDOOR).

Blue shaded cells are AHRI conditions. Green shaded cells are ACCA (TVA) conditions.

Multipliers for determining the performance with other indoor sections.

NOTE: For dry bulb temperatures different than those listed (between 73-87 °F), sensible capacity increases by 1060 BTUH per 1000 CFM per degree above the listed temperature and decreases by 1060 BTUH per 1000 CFM per degree below the listed temperature.

Air Handlers	Coils	T.C.	S.C.	KW
-	FC/MC62	1.00	1.00	1.00
-	FC64	1.03	1.05	1.00
AHE60D	-	1.01	1.03	0.96
AHV60D	-	0.99	0.97	0.99
MV20D	FC/MC62D	1.01	1.00	0.98
MV20D	FC64D	1.04	1.05	0.99
MX20DN21	FC/MC62D	1.00	0.99	0.95
MX20DN21	FC64D	1.02	1.03	0.95

Furnaces	Coils	T.C.	S.C.	KW
T*(8,L)C*C16	HD60	1.00	1.01	0.99
T*(8,L)C*C20	FC/MC62D	0.99	0.97	0.96
T*(8,L)C*C20	HD60	0.98	0.96	0.95
T*(8,L)V*C16	HD60	1.00	1.01	0.99
T*(8,L)V*C20	FC/MC62D	0.99	0.97	0.96
T*9(C,V)*C16	HD60	0.98	0.96	0.96
T*9(C,V)*C20	FC/MC62D	0.99	0.96	0.98
T*9(C,V)*C20	FC64D	1.02	1.01	0.99
T*9(C,V)*C20	HD60	0.98	0.96	0.97
T*9(C,V)*D20	FC/MC62D	0.99	0.96	0.97
T*9(C,V)*D20	FC64D	1.02	1.01	0.97

Furnaces	Coils	T.C.	S.C.	KW
T*9(C,V)*D20	HD60	0.98	0.96	0.97
TM8X100C20MP11	FC/MC62D	0.97	0.95	0.96
TM8X100C20MP11	FC64D	1.00	0.98	0.95
TM8X120C20MP11	FC/MC62D	0.97	0.95	0.96
TM8X120C20MP11	FC64D	1.00	0.98	0.95
TM9E100C20MP11	FC64D	0.99	0.95	0.96
TM9E120D20MP11	FC64D	0.99	0.95	0.96
TM9X100C20MP11	FC64D	0.99	0.95	0.96
TM9X120D20MP11	FC64D	0.99	0.95	0.96
TMLX100C20MP11	FC/MC62D	0.97	0.95	0.96
TMLX100C20MP11	FC64D	1.00	0.98	0.95
TMLX120C20MP11	FC/MC62D	0.97	0.95	0.96
TMLX120C20MP11	FC64D	1.00	0.98	0.95
Y*(8,L)C*C16	HD60	1.00	1.01	0.99
Y*(8,L)C*C20	FC/MC62D	0.99	0.97	0.96
Y*9C*C16	HD60	0.98	0.96	0.96
Y*9C*C20	FC/MC62D	0.99	0.96	0.98
Y*9C*C20	FC64D	1.02	1.01	0.99
Y*9C*D20	FC/MC62D	0.99	0.96	0.97
Y*9C*D20	FC64D	1.02	1.01	0.97